

Deerfield™/Foxfire™ Troubleshooting & Service Guide



TRAVIS INDUSTRIES
HOUSE OF FIRE

Copyright © 2018

Travis Industries Certified Factory Training Program



Models Addressed in this Guide	3	Flow Switch Removal	47
Who should use this guide.....	3	Metering Motor Removal	49
Precautions	3	User Interface (UI) Removal	50
Items to Bring on Service Calls	3	Troubleshooting the Appliance.....	52
Tools	3	Diagnostic Screens for User Interface Firmware Version	
Spare Parts	3	1.2.2 or less	53
Parts Identification and Part Numbers	4	Diagnostic Screens for User Interface Firmware Version	
Deerfield - Location of Components	5	1.2.3.....	54
Deerfield - Removal of Components.....	6	User Interface Error Codes.....	56
Visual Deflector and Burn Platform Removal	6	Sensor Status Lights.....	58
Fireback Removal	7	AC Status Lights.....	60
Rear Panel Removal	9	Testing AC Power at the Board	61
Push Auger Motor Removal	10	Testing DC voltage from the Push Auger Encoder	62
Power Control Board (PCB) Removal	12	Testing DC voltage from the Temperature Sensor	63
Metering Motor Removal	15	Normal Operation Flow Chart.....	64
Igniter Removal	16	Annual Service	66
Flow Switch Removal.....	18	Introduction.....	66
Convection Blower Removal	20	Recommended Tools for Service	66
Identifying a GEN 1 Combustion Blower vs. GEN 2		Recommended Supplies for Service.....	66
Combustion Blower	21	Clean the Venting System	67
GEN 1 Combustion Blower Removal	22	Clean convection blowers.....	67
GEN 2 Combustion Blower Removal	25	Clean and Inspect Vacuum Tube	68
Auger, Bushing Plate, and Block Removal.....	28	Clean the firebox, liners, and burn platform.....	68
Chisel Removal	30	Clean the horizontal exhaust passage.....	72
Horizontal Rotating Disks (HRD) Components Removal.....	32	Clean the Exhaust Blower Impellers and Housing	
User Interface (UI) Removal	36	(Deerfield).....	73
Foxfire - Location of Components.....	37	Clean the Exhaust Blower Impellers and Housing (Foxfire)	
Foxfire - Removal of Components	38	74
Visual Deflector and Burn Platform Removal	38	Check gaskets	74
Fireback Removal	38	Clean fines out of the HRD	75
Igniter Removal	38	Appendix A.....	76
Auger, Bushing Plate, and Block Removal.....	38	Wiring Diagram	76
Chisel Removal	38	Appendix B.....	77
Horizontal Rotating Disk (HRD) Component Removal	38	Control Timing	77
Side Panel Removal.....	39	Appendix C.....	78
Push Auger Motor Removal	40	Fan Voltages and Metering Motor Timing (FW 1.1.7).....	78
Convection Blower Removal	43	Fan Voltages and Metering Motor Timing (FW 1.1.10).....	79
Combustion Blower Removal	45	Appendix D.....	80
		Power Control Board Pinout	80



Models Addressed in this Guide

This guide addresses the Lopi Deerfield™ and Foxfire™ Stoves.

Who should use this guide

This guide was developed for service personnel and those selling Travis Industries products. Because of the inherent danger involved with heating appliances, all work must be done by qualified personnel only. The heater must be installed in accordance with the owner's manual and all local building codes. Bring an owner's manual for the heater being serviced in case any installation or maintenance questions arise.

Precautions



This heater becomes very hot during operation - use care to prevent burns or property damage while servicing.



Make sure the appliance is unplugged before conducting service or replacing a component. Some procedures may require the heater to be plugged in while diagnosing the problem. In these cases, use caution to prevent arcing or electrical shocks.



Before conducting service, lay down a drop cloth to prevent fly ash and other debris from staining the carpet or other flooring. On inserts, lay down a piece of cardboard on the hearth to prevent scratches.

Items to Bring on Service Calls

Tools

- Nut drivers
- Open-end & socket wrenches in 1/4", 5/16", 11/32", 3/8", 7/16", 1/2", 7/8", 1"
- Allen Wrenches
- Torx bits or drivers
- Multimeter
- Standard and Phillips-head Screwdrivers
- Wire with a male quick-connect attached to each end (called a jumper wire)

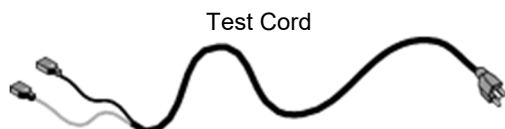







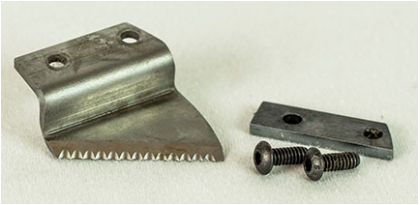
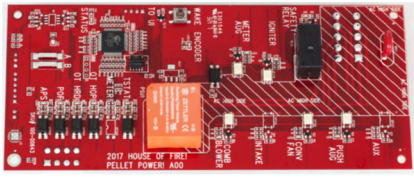

- Power cord with female quick-connects attached to the hot and common wires (called a hot wire)
- Ash Vacuum (or shop vacuum with drywall filter) and a bottle brush for cleaning the stove
- Lock Ties (for keeping all wires from contacting hot portions of the stove)
- Cleaner, paper towels, drop cloth, cardboard & other supplies to clean any fly ash entering home.

Spare Parts

- Circuit Board
- Metering Auger Motor
- Push Auger Motor
- Exhaust Blower
- Snap Disks (System & Hopper)
- Combustion Blower & Blower Gasket
- Convection Blower
- Heater Fuses (5 Amp Fast Acting - 1/4" x 1-1/4")
- Circuit Board Fuses (6 Amp 5 mm x 20 mm)
- Door Gasket and Gasket Cement
- Igniter
- Flow Switch



Parts Identification and Part Numbers

<p>Chisel 250-04138</p>		<p>Power Control Board 250-04443</p>	
<p>Convection Blower Left 250-04440 Right 250-04439</p>		<p>(FoxFire and Early Deerfield) GEN 1 Combustion Blower 250-03636</p>	
<p>Flow Switch 90-0791</p>		<p>GEN 2 Combustion Blower 250-05610</p>	
<p>Igniter 250-02613</p>		<p>Snap Disk (aka - System Disk or Proof of Fire) 250-02966</p>	
<p>Push Auger Motor (with encoder) 250-04442</p>		<p>Snap Disk (aka - High Limit Disk - Hoper Safety Disk - Safety Disk) 250-00314</p>	
		<p>High Torque Metering Motor (aka - HRD motor) 250-03633</p>	



Deerfield - Location of Components

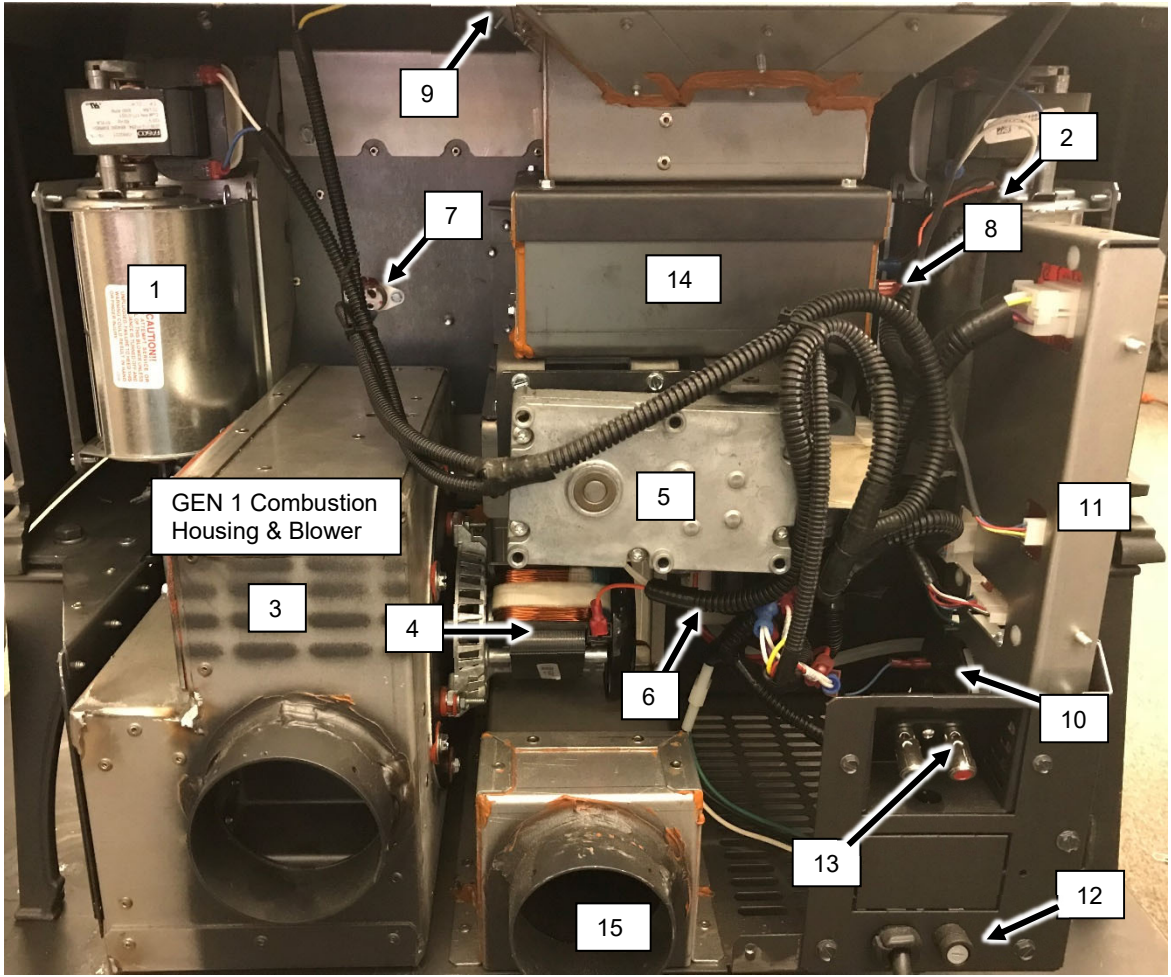

GEN 1 Combustion Housing & Blower

GEN 2 Combustion Housing & Blower

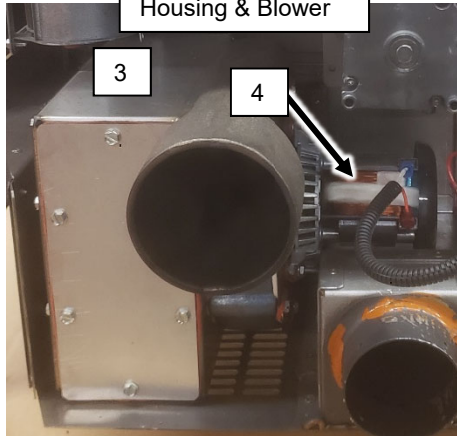

1	Right Convection Blower
2	Left Convection Blower
3	Exhaust Box
4	Combustion Blower
5	Push Auger Motor
6	Metering Motor
7	System Disk
8	HRD High Limit Disk
9	Hopper High Limit Disk
10	Flow Switch
11	Power Control Board
12	Fuse Holder
13	Thermostat Connectors
14	HRD
15	Air Intake



Deerfield - Removal of Components

Visual Deflector and Burn Platform Removal



Make sure the stove has fully cooled (approximately 25 minutes) before conducting service. Unplug the stove to prevent electrical shock.

1. Grab the front, middle of the visual deflector, and lift up slightly to release the hooks from the pins on the side of the housing (see below).



2. Lift the locking key upward to release the burn platform from the stove (see below).

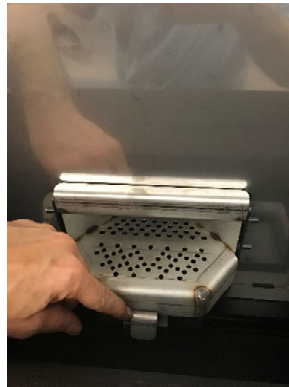

3. Grab the upper portion of the Burn Platform and pull forward. Once the hole in the back of the burn platform clears the auger tube, you can angle the platform up and remove it from the stove.





Fireback Removal



Make sure the stove has fully cooled (approximately 25 minutes) before conducting service. Unplug the stove to prevent electrical shock.

1. Remove the visual deflector and burn platform (see section “Visual Deflector and Burn Platform Removal”).

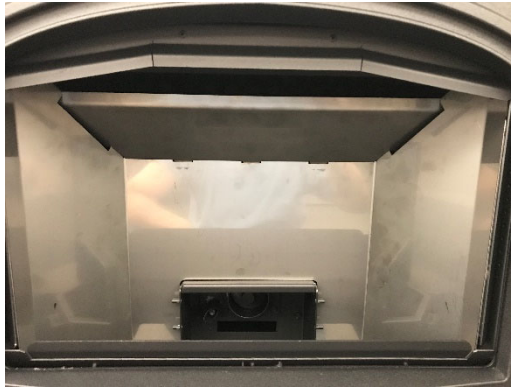

2. Lift the top center panel of the fireback up to release it from the notches on the lower panels. Lower one side and guide the panel out of the firebox.



3. Lift up on one of the side panels to release the (2) tabs on the bottom of the panel from the notches in the firebox. Guide the bottom of the panel forward until it can be lowered into the ashpan area.

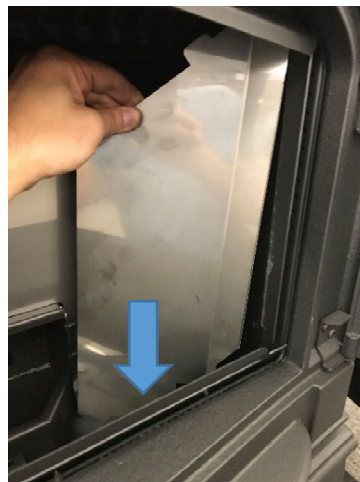
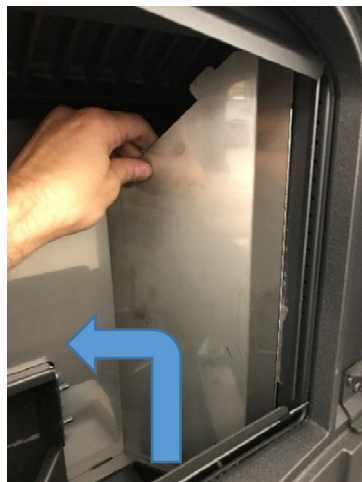



4. Tip the top edge of the side panel forward and guide the panel out of the firebox.

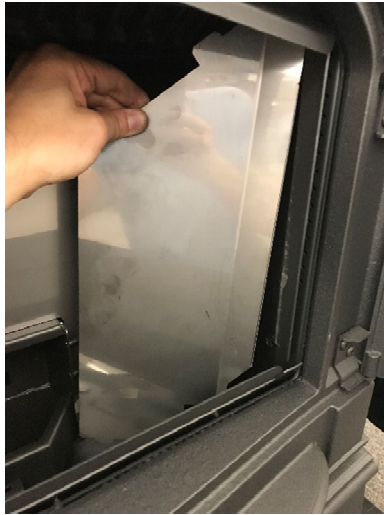

5. Repeat the same process for the other side fireback.
6. The rear fireback is between the back of the fireback and the mounting studs for the visual deflector. Lift the rear fireback straight up until the legs of the fireback can clear the mounting studs. Tilt it forward and guide it out of the firebox.

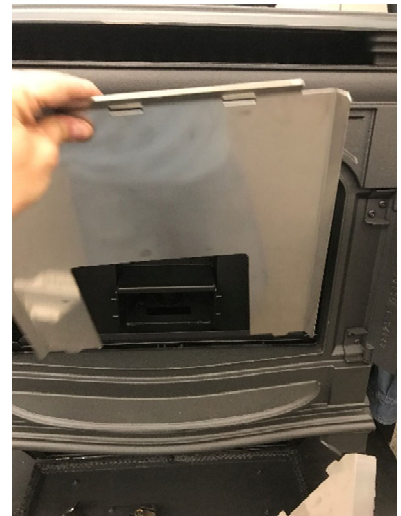

7. The back of the firebox is now visible





Rear Panel Removal



Make sure the stove has fully cooled (approximately 25 minutes) before conducting service. Unplug the stove to prevent electrical shock.

1. Remove the (3) 5/16" screws along the top and (3) additional screws along the bottom of the back panel. Lift up on the panel using the handle on the top edge to disengage the bottom of the panel from the floor of the stove. Set the screws aside for reinstallation.





Push Auger Motor Removal



Make sure the stove has fully cooled (approximately 25 minutes) before conducting service. Unplug the stove to prevent electrical shock.

1. Remove the rear panel (see section "Rear Panel Removal").
2. The push auger motor is the motor that is directly above the air intake of the stove and is facing horizontally.



3. Use a 3/16" Allen wrench to loosen the retaining screw. If you only remove the screw enough to allow the shaft of the motor to become free, the collar will stay in place making for easier re-installation of the auger motor.

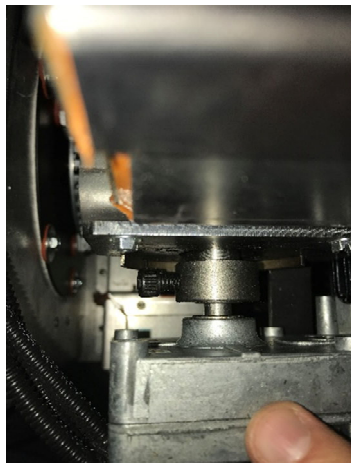
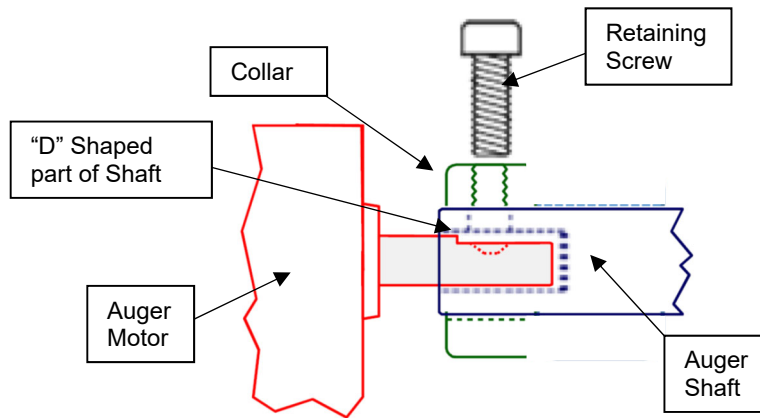



4. Disconnect the two power wires on the motor from the wire harness at the quick connects.
5. Disconnect encoder wires from the motor. Carefully use a flat screwdriver to separate the white connector (see below).

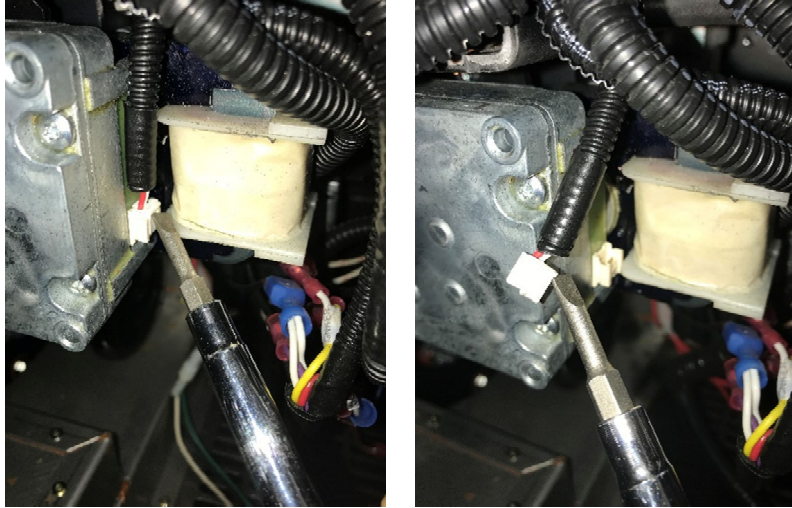

6. Slide the push auger motor straight back to disengage it from the auger shaft.

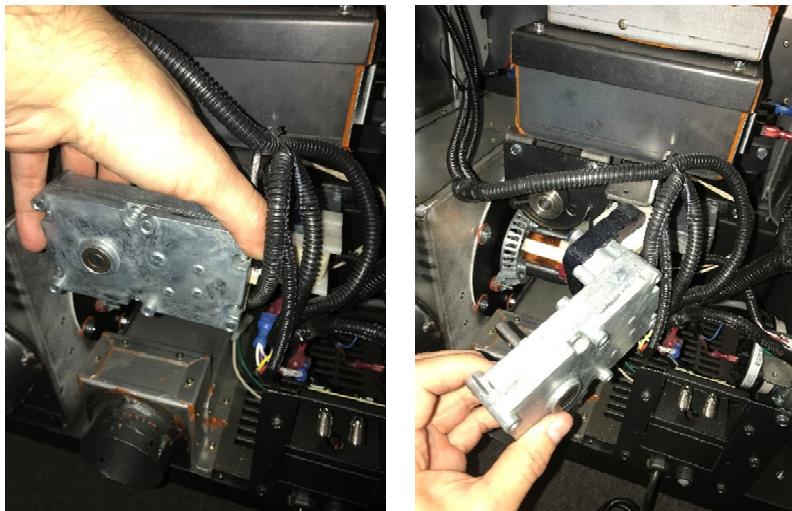

NOTE: When re-installing the auger motor make sure that the retaining screw is seated against the flat portion of the “D” shaped portion of the auger shaft.



Power Control Board (PCB) Removal



Unplug the stove to prevent electrical shock.

1. Remove the rear panel (see section "Rear Panel Removal").

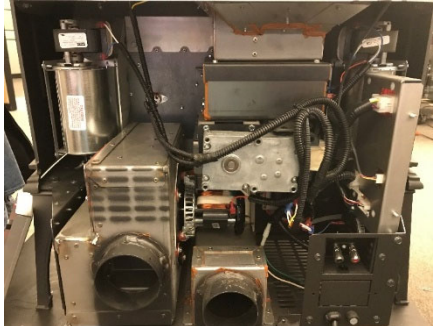

2. Gently pull the PCB away from the metal shield that surrounds it to gain access to the back of the board. You may need to assist some of the wire harnesses through the shield behind the board. The board is held in place by a clip in each corner.

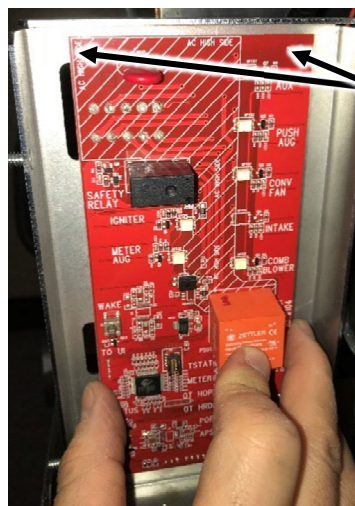

Pull forward to disengage the PCB from clips.

3. Press the (2) tabs on the sides of the 10 pin Molex plug (supplies AC power to the PCB) and disconnect it from the board.

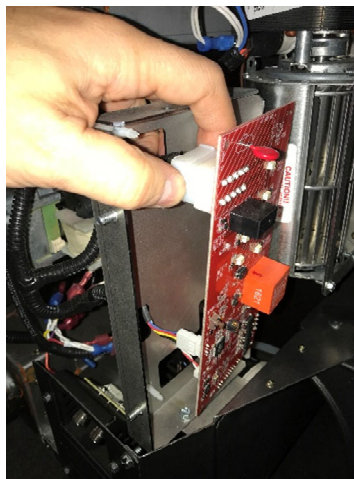



4. With a flat head screwdriver, gently pry the tab back on the Molex from the User Interface and disconnect it from the board.

NOTE: Be careful not to bend the tab further than needed to release it from the board.



5. Press the tab on the safety circuit Molex on the board to release it. Disconnect it from the board.

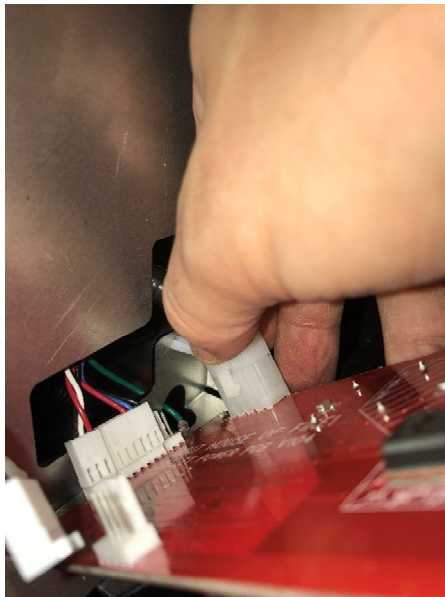



- The long flat Molex at the bottom of the board is actually two separate connectors. The smaller of the two is from the encoder on the push auger motor. The larger connector is from the external thermostat. These connectors have the same type of tab on it as the User Interface connector. Pry the tab back slightly and disconnect the connectors from the board.

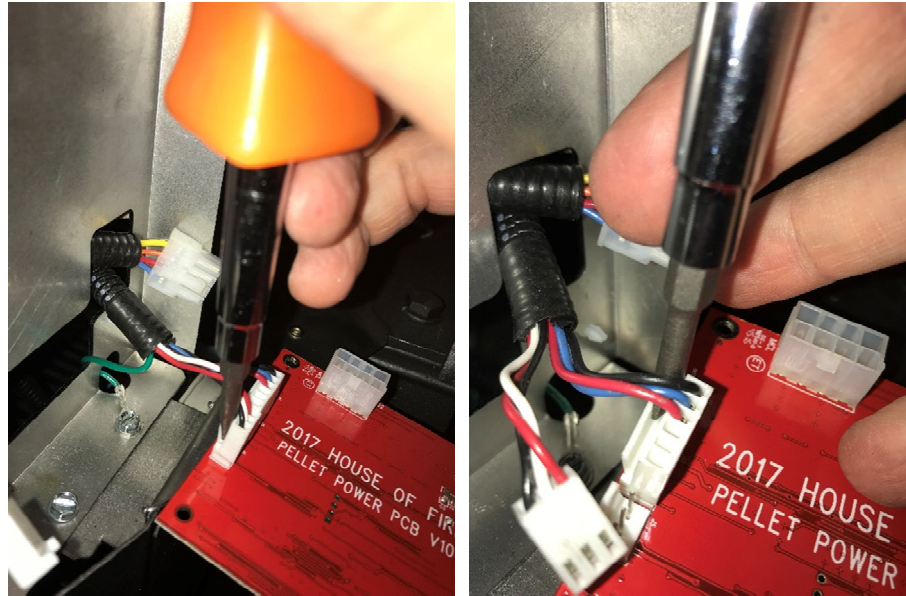

- If you are removing the board to gain access to other components, you will now want to remove the metal heat shield Using a $\frac{1}{4}$ " nut driver to remove the (2) screws at the bottom of the shield. When reinstalling the shield **make sure that the green ground wire is reconnected.**

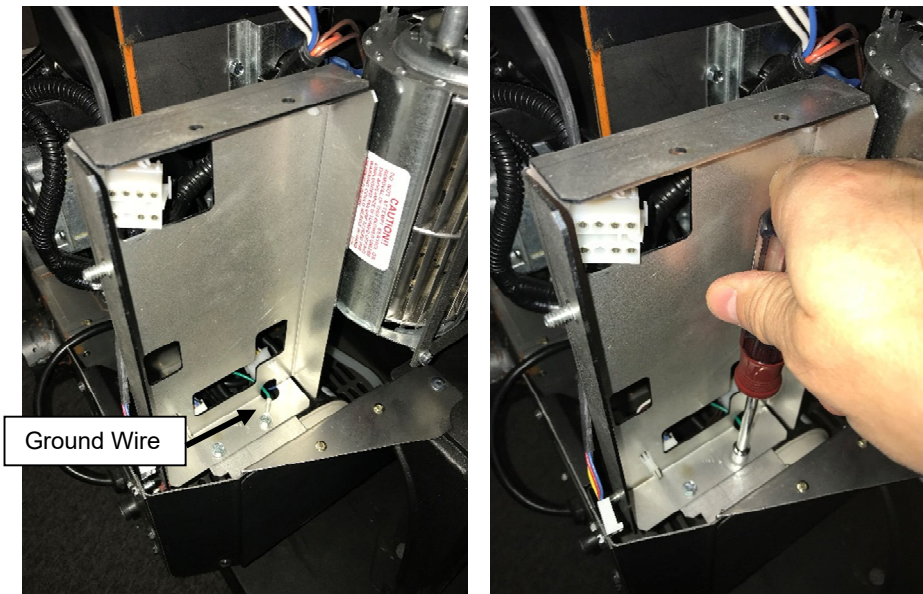



Metering Motor Removal



Make sure the stove has fully cooled (approximately 25 minutes) before conducting service. Unplug the stove to prevent electrical shock.

1. Remove the rear panel (see section "Rear Panel Removal").
2. Remove the Power Control Board and heat shield (see section "Power Control Board Removal").
3. Remove the Exhaust Box (see section "Exhaust Box Removal").
4. Disconnect the two wires on the motor from the wire harness at the quick connects.
5. Depending on where the retaining screw ends up in the rotation of the HRD, you may need to remove the left convection blower (see section "Convection Blower Removal").
6. Use a 3/16" Allen wrench to loosen the retaining screw. If you only remove the screw enough to allow the shaft of the motor to become free, the collar and spacer will stay in place making for easier re-installation of the auger motor.

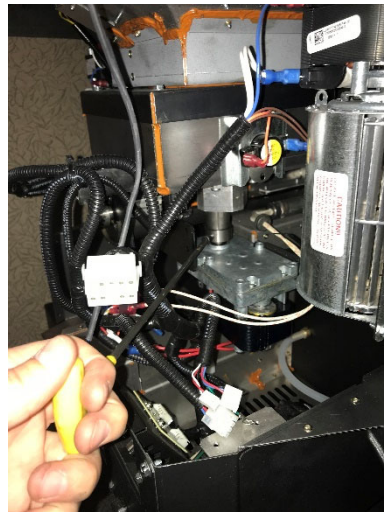
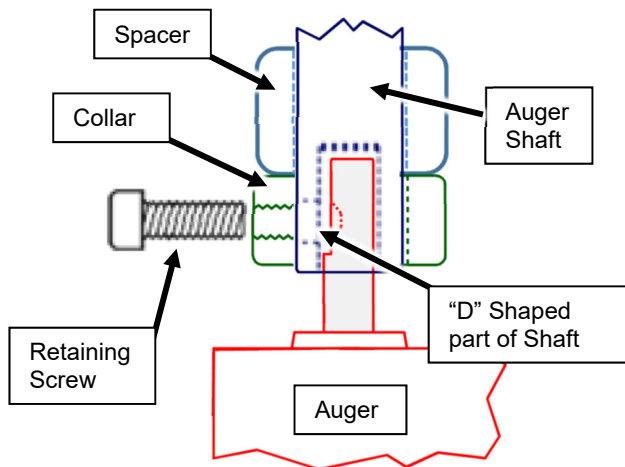

NOTE: When re-installing the auger motor make sure that the retaining screw is seated against the flat portion of the "D" shaped portion of the auger shaft.



Igniter Removal



Make sure the stove has fully cooled (approximately 25 minutes) before conducting service. Unplug the stove to prevent electrical shock.

1. Remove the rear panel of the stove (see rear panel removal).
2. Using a $\frac{1}{4}$ " nut driver remove the zip tie anchor from the back of the stove. The anchor is located just below and to the left of the right blower (facing the back).

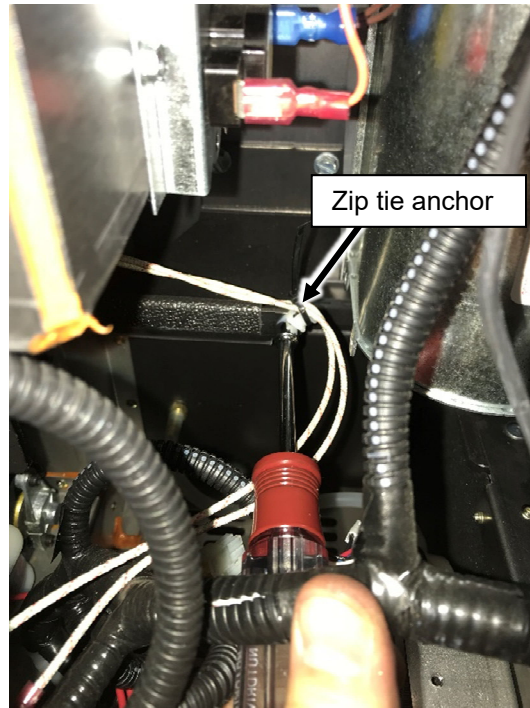

3. Disconnect the two white wires from the wiring harness at the quick connects.
4. Open the front door of the stove and remove the visual deflector and the burn platform (see section "Visual Deflector and Burn Platform Removal").
5. Locate the igniter to the left of the push auger tube.





6. Remove the 3/8" bolt that secures the igniter to the firebox (set bolt aside for reinstallation).



7. Pull the igniter forward and work the wires through the hole.





Flow Switch Removal



Make sure the stove has fully cooled (approximately 25 minutes) before conducting service. Unplug the stove to prevent electrical shock.

1. Remove the rear panel of the stove (see rear panel removal).
2. The Flow Switch is located directly below the left-hand convection blower. Removal of the left blower is not required but the removal of the fan will give better access to the Flow Switch (see section "Blower Removal").
3. Use a 3/8" nut driver to remove the two locknuts that mount the switch to the stove (set aside for reinstallation). The nuts are located on the side nearest the rear of the stove.

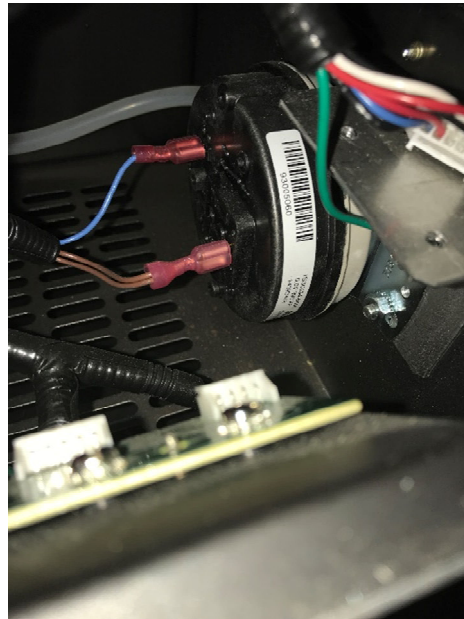

4. Disconnect the two wires from the wiring harness at the quick connects (orientation does not matter for reinstallation).

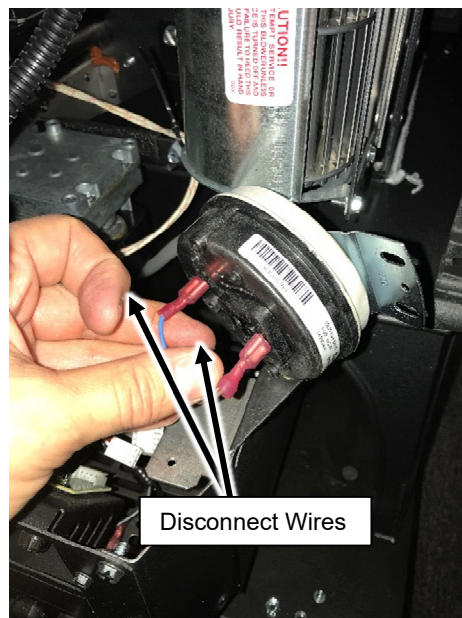



5. Remove the vacuum hose from the flow switch





Convection Blower Removal



Make sure the stove has fully cooled (approximately 25 minutes) before conducting service. Unplug the stove to prevent electrical shock.



Both blowers remove the same way. If the left blower is being removed, remove the PCB and shield first (see section "PCB removal")

1. Remove the side rear panel (see section "Rear Panel Removal")
2. Remove the (4) screws that mount the blower to the mounting bracket (set aside for reinstallation).

NOTE: The rear two screws can be removed with a nut driver. The front (2) will require a small ratchet or box wrench.



3. Remove the fan from the stove and disconnect the wires from the motor.

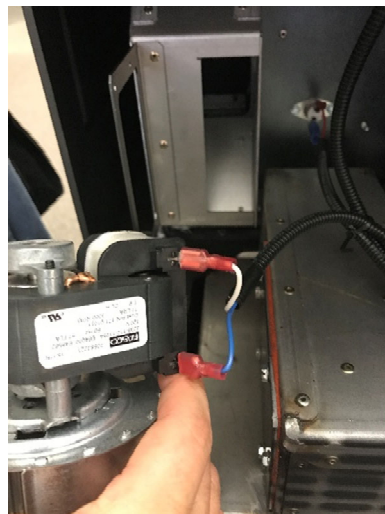

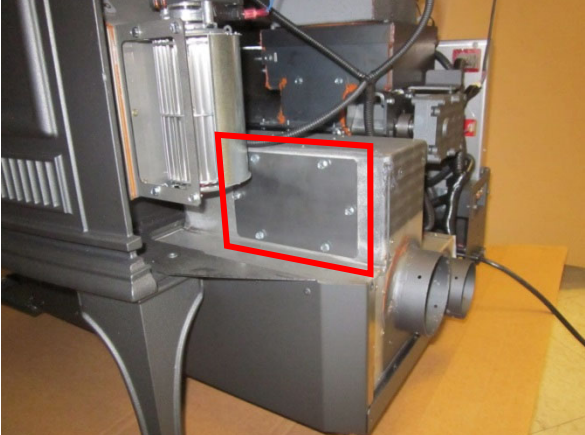
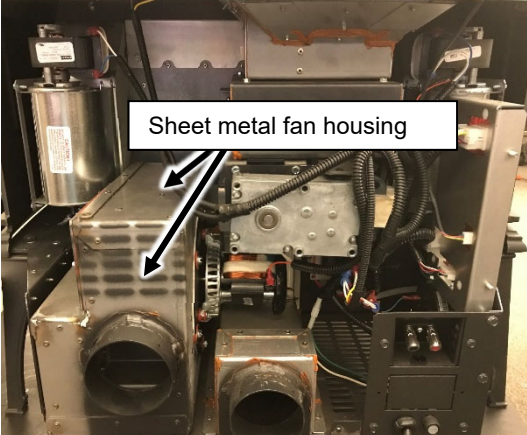
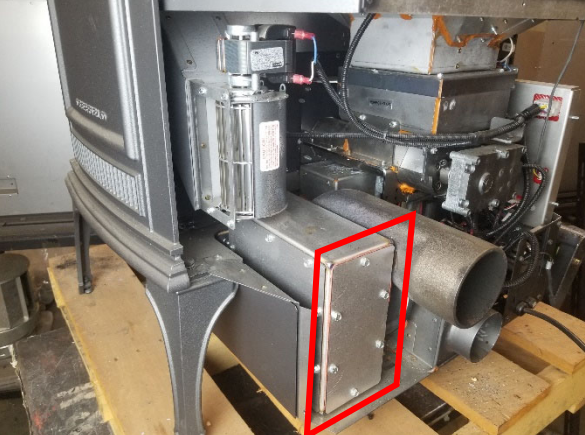
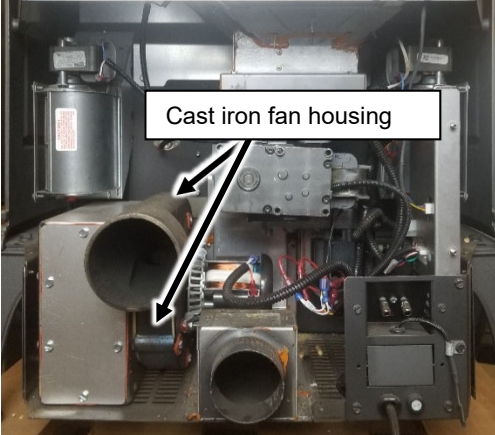

Identifying a GEN 1 Combustion Blower vs. GEN 2 Combustion Blower

GEN 1 - Blower Housing	GEN 1 – Rear View
 A side view of a GEN 1 combustion blower housing. A red rectangular box highlights a cleanout panel on the side of the housing.	 A rear view of a GEN 1 combustion blower. A white box with the text "Sheet metal fan housing" has two arrows pointing to the fan housing assembly.
<p>GEN 1 – Combustion blower has a cleanout on the side of the blower housing.</p>	<p>GEN 1 – Combustion blower bolts directly to the sheet metal fan housing. The exhaust outlet comes out of the sheet metal box.</p>
GEN 2 - Blower Housing	GEN 2 – Rear View
 A side view of a GEN 2 combustion blower housing. A red rectangular box highlights a cleanout panel on the rear portion of the housing.	 A rear view of a GEN 2 combustion blower. A white box with the text "Cast iron fan housing" has two arrows pointing to the fan housing assembly.
<p>GEN 2 – Combustion blower has a cleanout on the rear portion of the blower housing.</p>	<p>GEN 2 – Combustion blower bolts into a cast iron fan housing. The exhaust outlet comes out of the cast iron blower housing.</p>



GEN 1 Combustion Blower Removal



Make sure the stove has fully cooled (approximately 25 minutes) before conducting service. Unplug the stove to prevent electrical shock.

2. Disconnect the venting from the stove.
3. Open the ash pan door and remove the ash pan from the appliance.



4. Remove the exhaust cover plate by removing the wingnut on the left side and pulling the left side of the plate forward and pulling the plate free of the stove. Set the wing nut and plate aside for reinstallation.



5. Locate the (6) bolts around the exhaust port in the rear of the ash pan cavity. Depending on the amount of use the stove has had, you may want to apply penetrating oil and allow it to sit for a few minutes before removing the bolts. Use a 3/8" nut driver or ratchet for removal. Set the bolts aside for reinstallation.

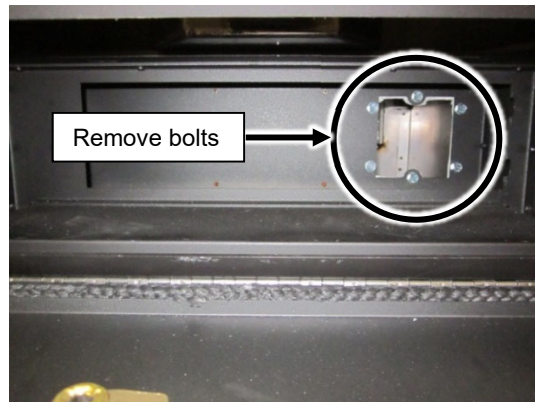



- Remove the (3) 5/16" screws along the top and (3) additional screws along the bottom of the back panel. Lift up on the panel using the handle on the top edge to disengage the bottom of the panel from the floor of the stove. Set the screws aside for reinstallation.

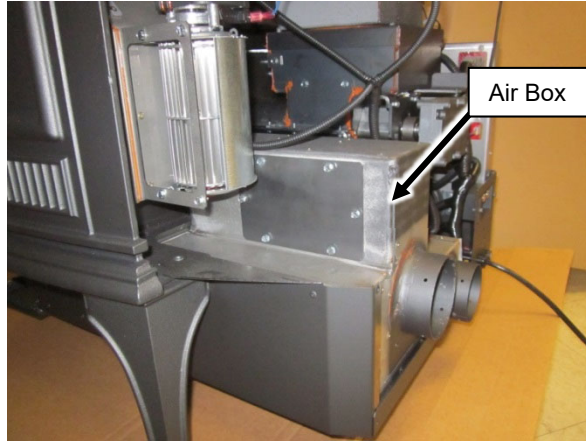

- Locate the two wires that power the fan motor (orange and grey). Disconnect the wires from the motor. Make sure not to damage the connectors on the wires while removing.

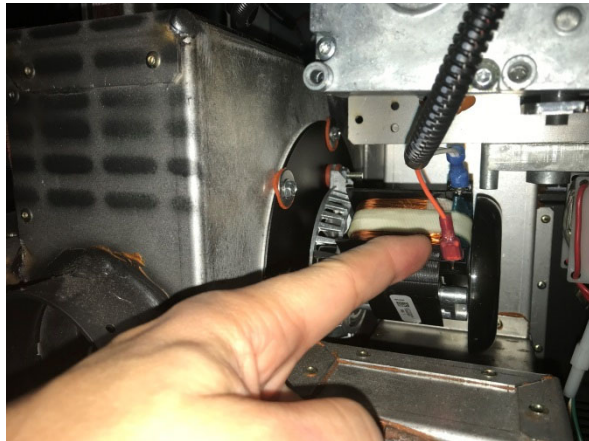

- The exhaust box is now loose in the stove. Lift the box up and gently remove it from the stove.

NOTE: It is a tight fit for the fan motor to fit between the push auger motor and the stove but it will fit. If you prefer, you can remove the push auger motor to allow more room.

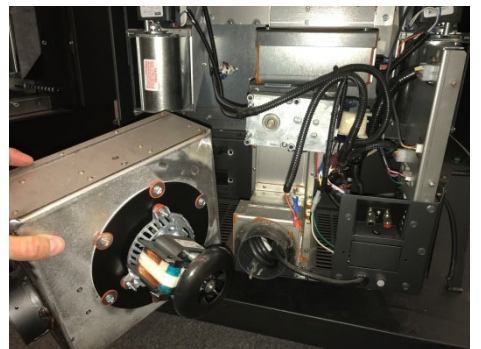
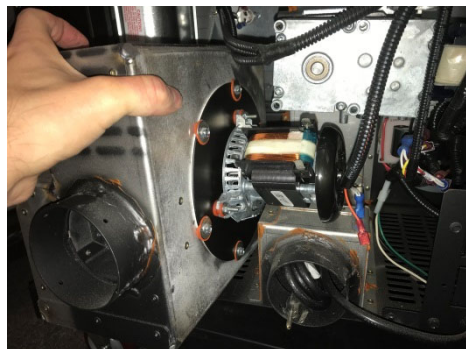
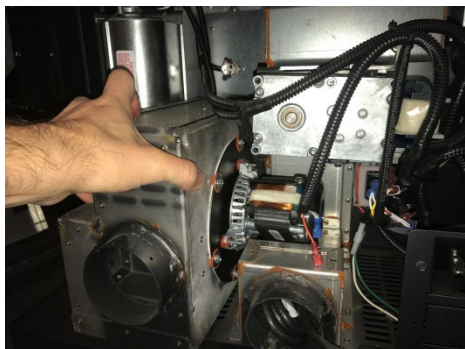



9. Disconnect the exhaust blower from the exhaust box by removing the (6) bolts shown below. Use a 5/16" nut driver. **Set bolts, washers, and orange spacers aside for reinstallation.**

NOTE: Pay attention to the orientation of the blower to the exhaust box. When reinstalling the blower back into the exhaust box, it will need to be oriented with the electrical connections in the 10 o'clock position (with the exhaust box outlet on the left) as shown in the picture below.

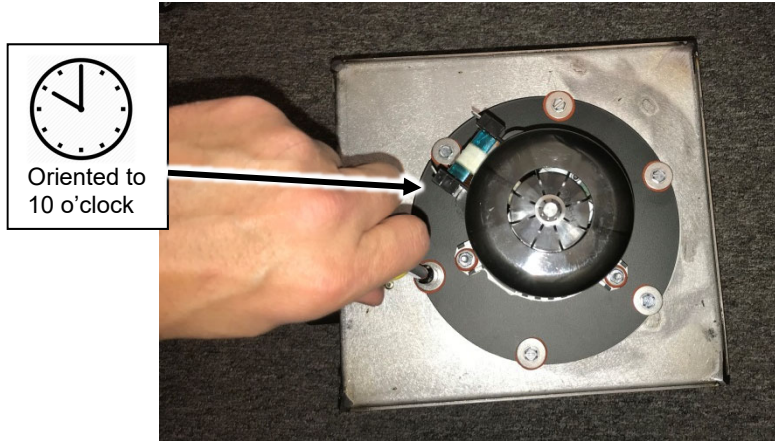

10. Carefully remove the fan from the exhaust box by lifting it straight up. Take care not to damage or bend the exhaust blower impellers.



11. Remove the circular white gasket from the fan. Install the exhaust blower into the new exhaust box (make sure the exhaust blower gasket is in position) and secure it with the six bolts, washers, and spacers removed from the old box. Make sure the blower is oriented to 10 o'clock when reinstalling (See step 8).



GEN 2 Combustion Blower Removal



Make sure the stove has fully cooled (approximately 25 minutes) before conducting service. Unplug the stove to prevent electrical shock.

1. Disconnect the venting from the stove.
2. Open the ash pan door and remove the ash pan from the appliance.



3. Remove the exhaust cover plate by removing the wingnut on the left side and pulling the left side of the plate forward and pulling the plate free of the stove. Set the wing nut and plate aside for reinstallation.



4. Locate the 6 bolts around the exhaust port in the rear of the ash pan cavity. Depending on the amount of use the stove has had, you may want to apply penetrating oil and allow it to sit for a few minutes before removing the bolts. Use a 3/8" nut driver or ratchet for removal. Set the bolts aside for reinstallation.

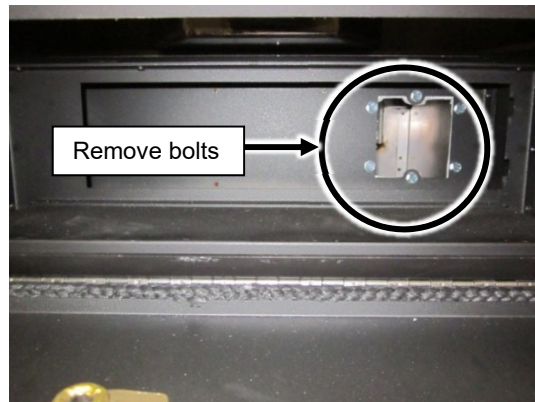



5. Remove the (3) 5/16" screws along the top and (3) additional screws along the bottom of the back panel. Lift up on the panel using the handle on the top edge to disengage the bottom of the panel from the floor of the stove. Set the screws aside for reinstallation.

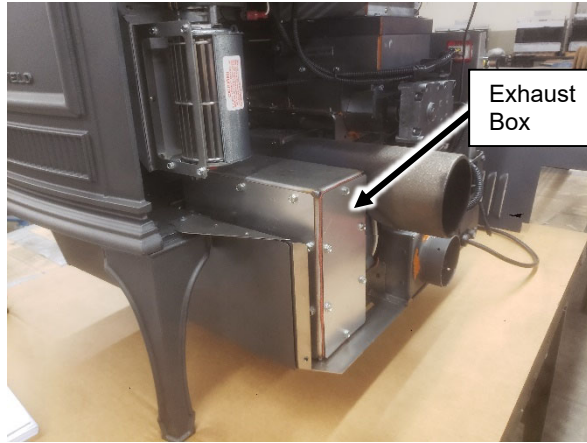

6. Locate the two wires that power the fan motor (orange and grey). Disconnect the wires from the motor. Make sure not to damage the connectors on the wires while removing.

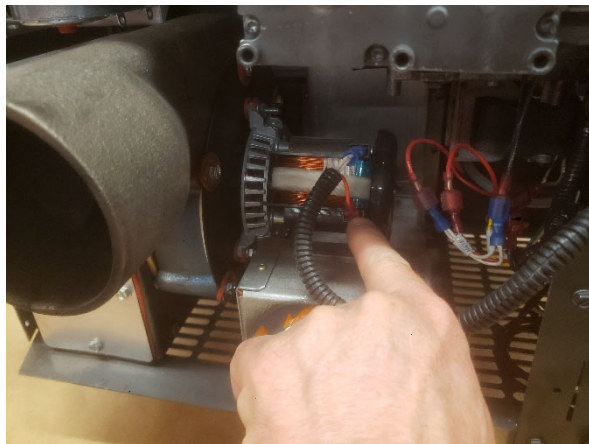

7. The exhaust box is now loose in the stove. Lift the box up and gently remove it from the stove.

NOTE: It is a tight fit for the fan motor to fit between the push auger motor and the stove but it will fit. If you prefer, you can remove the push auger motor to allow more room.

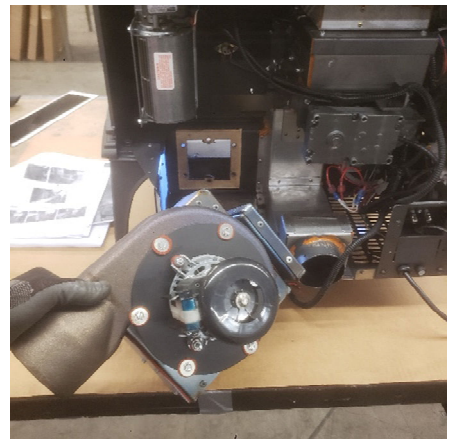
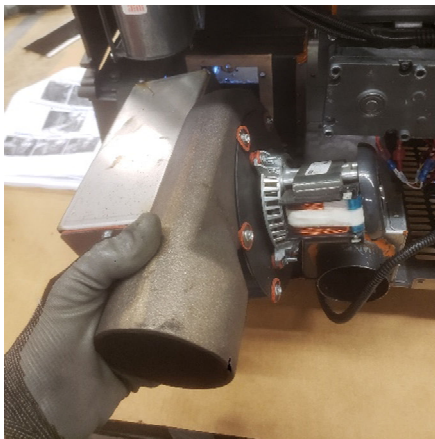



8. Disconnect the exhaust blower from the exhaust box by removing the (6) bolts shown below. Use a 5/16" nut driver. **Set bolts, washers, and orange spacers aside for reinstallation.**

NOTE: Pay attention to the orientation of the blower to the exhaust box. When reinstalling the blower back into the exhaust box, it will need to be oriented with the electrical connections in the 10 o'clock position (with the exhaust box outlet on the left) as shown in the picture below.

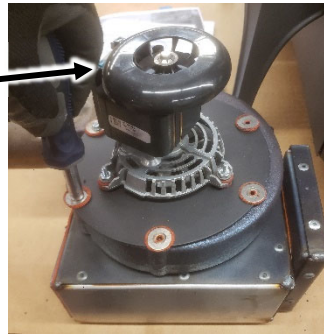
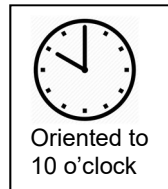

9. Carefully remove the fan from the exhaust box by lifting it straight up. Take care not to damage or bend the exhaust blower impellers.



10. Remove the circular white gasket from the fan. Install the exhaust blower into the new exhaust box (make sure the exhaust blower gasket is in position) and secure it with the six bolts, washers, and spacers removed from the old box. Make sure the blower is oriented to 10 o'clock when reinstalling (See step 8).



Auger, Bushing Plate, and Block Removal



Make sure the stove has fully cooled (approximately 25 minutes) before conducting service. Unplug the stove to prevent electrical shock.

1. Remove the rear panel (see section "Rear Panel Removal").
2. Remove the Push Auger Motor (see section "Push Auger Motor Removal").
3. Remove the Visual Deflector and Burn Platform (see section "Visual Deflector and Burn Platform")
4. Reach into the auger tube and hook your finger around the auger flight. Pull the auger flight assembly forward.
5. Use a $\frac{1}{4}$ " nut driver to remove the (2) screws that mount the bushing plate to the Mounting brackets on the HRD (set the screws aside for reinstallation).



6. Use a T20 Torx bit to remove the (4) screws that mount the bushing plate to the bushing block (set the screws aside for reinstallation).





7. Push the auger shaft forward so that it is flush with the outer edge of the brass bushing. Slide the bushing plate up to disengage the tab on the bottom of the plate from the notch in the auger tube (see below).

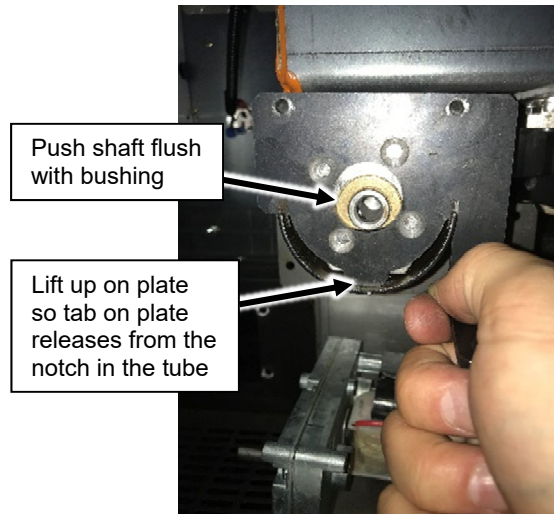

8. Remove the bushing block by sliding it straight back, out of the end of the auger tube.



9. Go around to the front of the stove. Reach into the end of the push auger tube, pull the auger flight forward and remove it from the tube.





Chisel Removal



Make sure the stove has fully cooled (approximately 25 minutes) before conducting service. Unplug the stove to prevent electrical shock.

1. Remove all pellets from the hopper.
2. Using a $\frac{1}{4}$ " nut driver remove the (6) $\frac{1}{4}$ " screws that secure the HRD access panel to the hopper (set aside for reinstallation).



3. Remove the HRD access panel. This will expose the top of the HRD assembly.
NOTE: You may want to use gloves when removing the plate to protect yourself from sharp edges.





4. Use a 1/8" Allen wrench to remove the (2) 1/4-20 x 1/2" screws that secure the chisel to the disk and remove the chisel.

NOTE: The chisel is very sharp. Handle with care.



5. Remove the chisel spacer.





Horizontal Rotating Disks (HRD) Components Removal



Make sure the stove has fully cooled (approximately 25 minutes) before conducting service. Unplug the stove to prevent electrical shock.



It is very important that all of the internal components of the HRD assembly be reinstalled in the same order as they were removed **and in the same orientation**. We recommend that you create a space where you can lay the parts out in order as you dismantle the HRD and clean the assembly to help ensure that the installation order is maintained.



When the HRD is reinstalled, make sure that when you look down through the HRD assembly you can not see through the assembly, into the auger flight. If you can, you have changed the orientation of some of the internal components. Contact Travis Industries Technical Support for assistance.

1. Remove all pellets from the hopper.
2. Using a 1/4" nut driver remove the (6) 1/4" screws that secure the HRD access panel to the hopper (set aside for reinstallation).



3. Remove the HRD access panel. This will expose the top of the HRD assembly.
NOTE: You may want to use gloves when removing the plate to protect yourself from sharp edges.

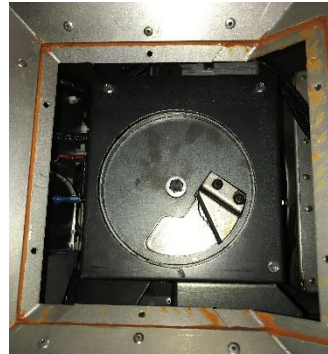

4. Remove the three 1/4" screws on the top of the HRD assembly (set aside for reinstallation)

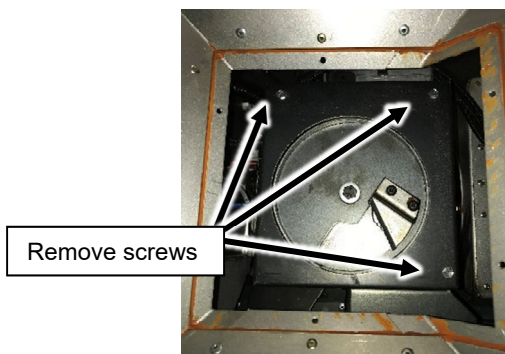



5. Remove the cover from the HRD assembly.

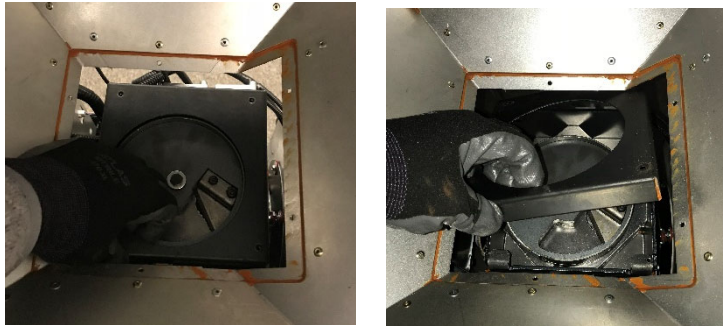

6. Use a 7/16" wrench to remove the bolt from the center of the HRD (set aside for reinstallation). Remove the top fuel-metering disk

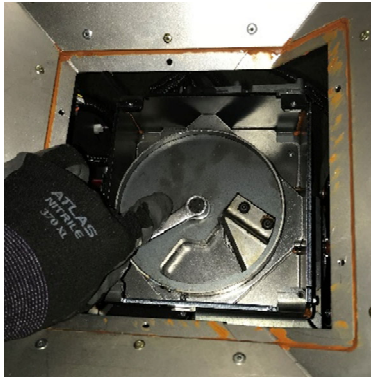

7. Remove the fuel metering/chisel assembly disk (has the chisel attached).

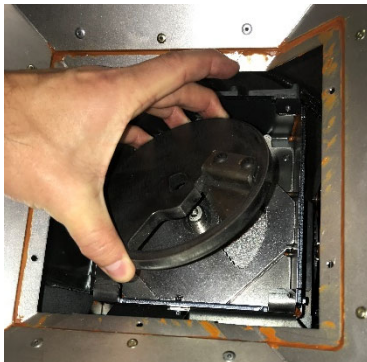

8. Remove the thin metal spacer from the auger shaft (set aside for reinstallation).





9. Remove the (3) fuel cup slide plates



10. Remove the thin metal spacer from the auger shaft (set aside for reinstallation).



11. Remove the bottom fuel-metering disk



12. Remove the thin metal spacer from the auger shaft (set aside for reinstallation).

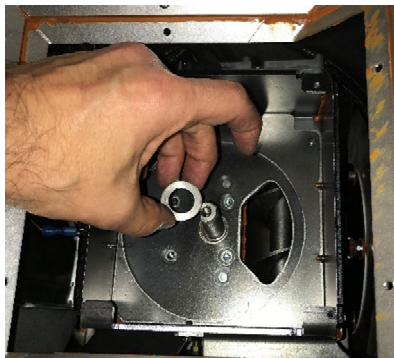



13. Remove the (2) bottom fuel meter spacer plates.

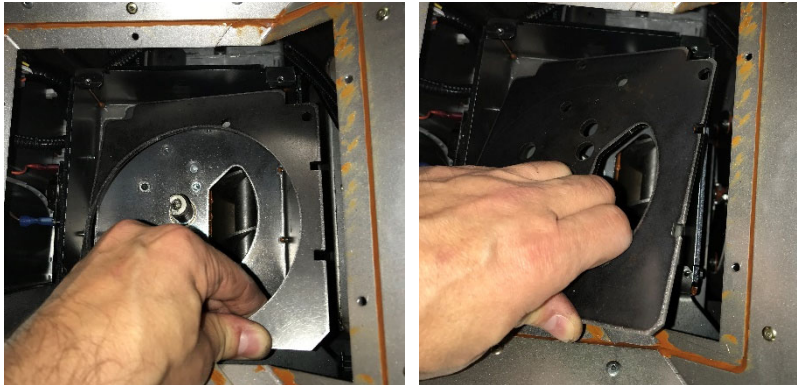

NOTE: The spacers can be removed without removing the snap disk bracket on the left side of the HRD but it is much easier to remove them with the bracket screws removed.

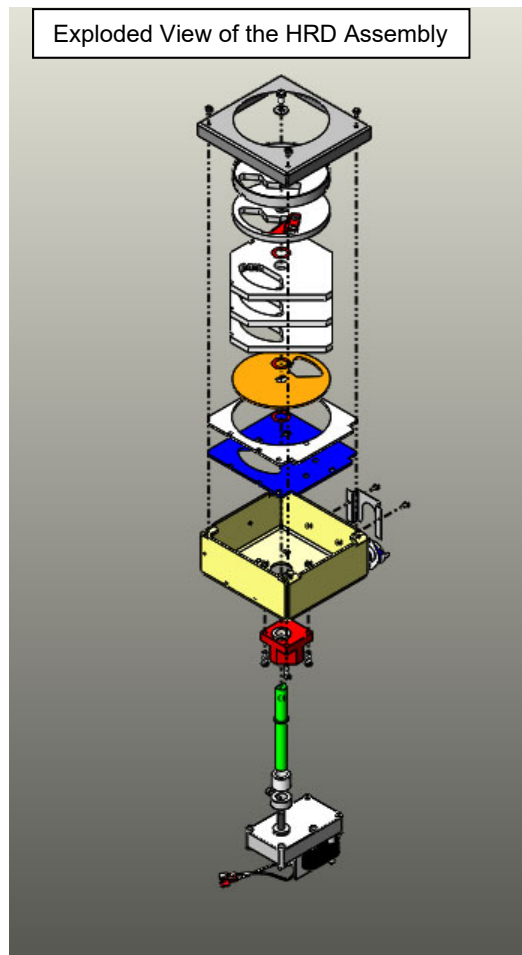



User Interface (UI) Removal

The process is the same as the Foxfire (see section "User Interface (UI) Removal" on pg.50).



Foxfire - Location of Components

Right Side (facing front of stove)

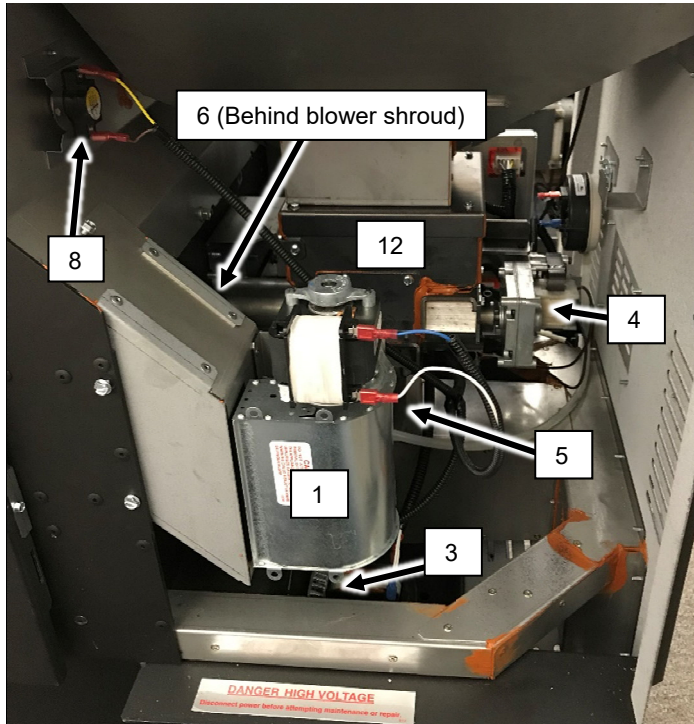

Left Side (facing front of stove)

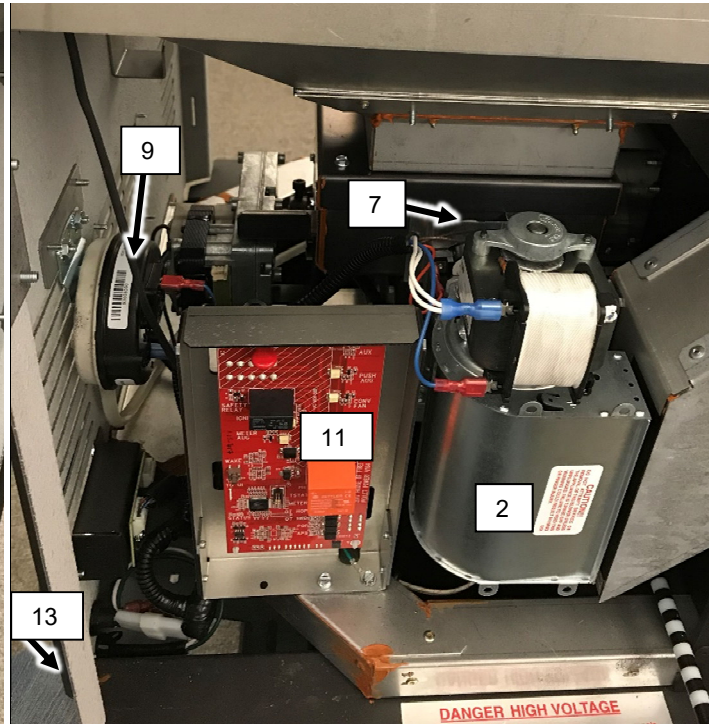

1	Right Convection Blower
2	Left Convection Blower
3	Combustion Blower
4	Push Auger Motor
5	Metering Motor
6	System Disk
7	HRD High Limit Disk
8	Hopper High Limit Disk
9	Flow Switch
11	Power Control Board
12	HRD
13	Fuse Holder



Foxfire - Removal of Components

Visual Deflector and Burn Platform Removal

The process is the same as the Deerfield (see section "Visual Deflector and Burn Platform Removal" on pg. 6).

Fireback Removal

The process is the same as the Deerfield (see section "Fireback Removal" on pg. 7)

Igniter Removal

The process is the same as the Deerfield (see section "Igniter Removal" on pg. 16)

Auger, Bushing Plate, and Block Removal

The process is the same as the Deerfield (see section "Auger, Bushing Plate, and Block Removal" on pg. 25)

Chisel Removal

The process is the same as the Deerfield (see section "Chisel Removal" on pg. 30)

Horizontal Rotating Disk (HRD) Component Removal

The process is the same as the Deerfield (see section "Horizontal Rotating Disk (HRD) Component Removal" on pg. 32)



Side Panel Removal



Make sure the stove has fully cooled (approximately 25 minutes) before conducting service. Unplug the stove to prevent electrical shock.

1. (Left panel only) Push the air restrictor rod all the way in and unscrew the knob from the end of the restrictor rod (set aside for reinstallation).



2. Remove the fastener on the back edge of the side panel. There is one screw for each panel.

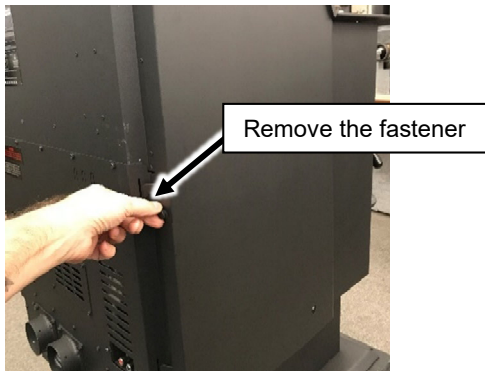

3. Slide the panel backward slightly to release the small tab on the upper rear portion of the panel from the slot on the stove.

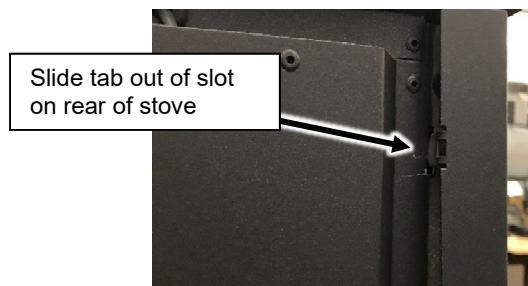

4. Slide the panel back further to disengage the front tabs from the stove. The panel is now free and can be set aside.

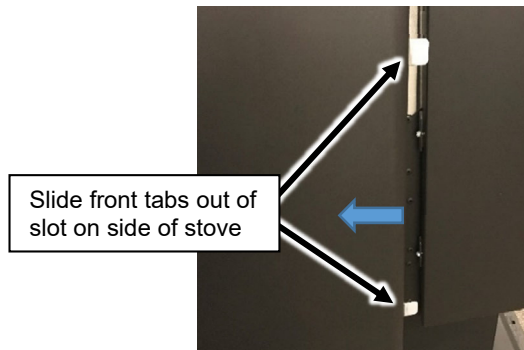



Push Auger Motor Removal



Make sure the stove has fully cooled (approximately 25 minutes) before conducting service. Unplug the stove to prevent electrical shock.

1. Remove both side panels (see section "Side Panel Removal"). Locate the set screw and locking collar between the bushing plate and the Push Auger Motor (whichever way the set screw is facing is the side you want to perform the rest of the procedure from (in the example below it is being shown from the right side of the stove).
2. The push auger motor is the motor that is directly above the air intake of the stove and behind the HRD assembly. The auger motor is oriented horizontally.



3. Use a 3/16" Allen wrench to loosen the retaining screw. If you only remove the screw enough to allow the shaft of the motor to become free, the collar will stay in place making for easier re-installation of the auger motor.

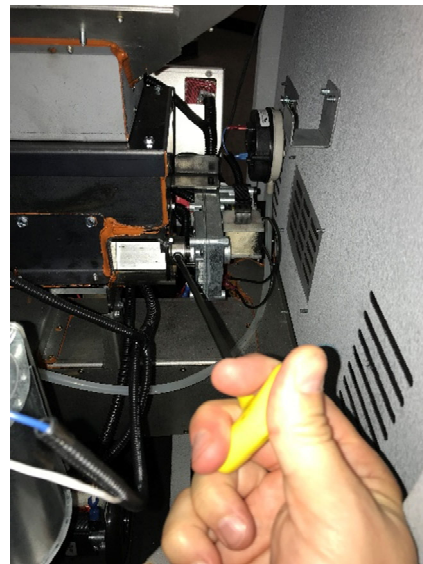
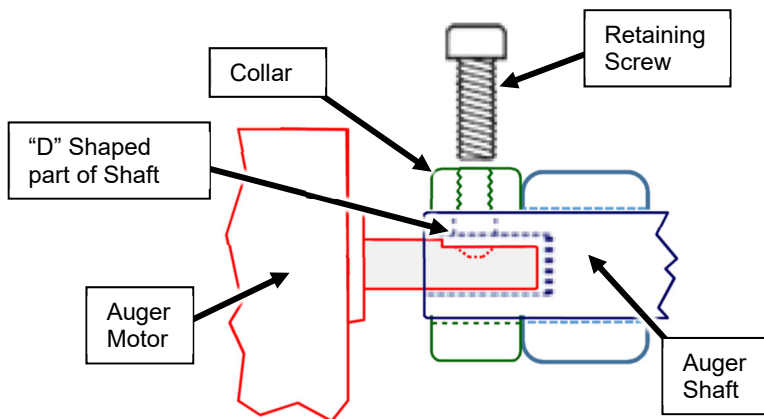



4. Disconnect the two wires on the motor from the wire harness at the quick connects.

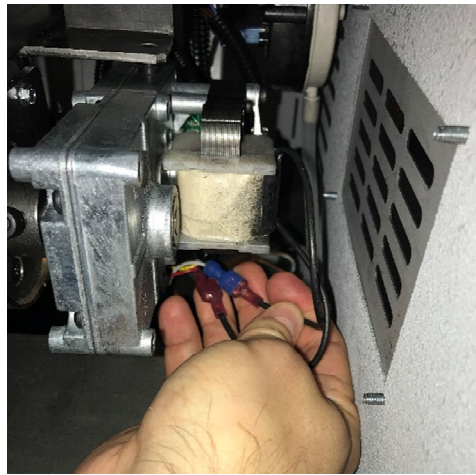

5. Disconnect encoder wires from the motor. Carefully use a flat screwdriver to separate the white connector (see below).

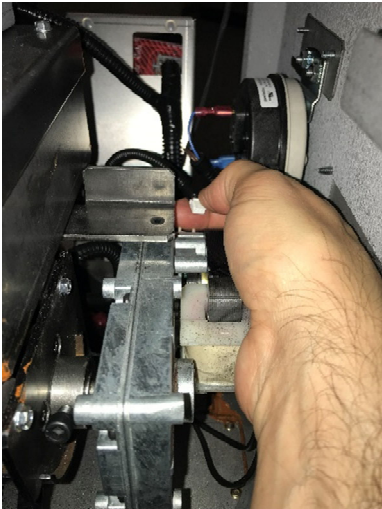



6. Slide the push auger motor straight back to disengage it from the auger shaft.

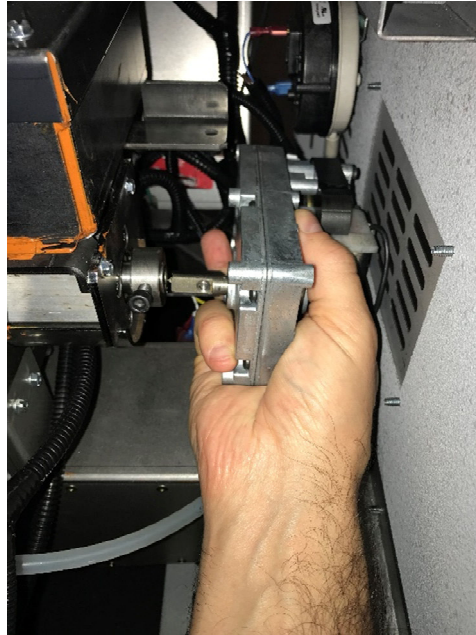

NOTE: When re-installing the auger motor make sure that the retaining screw is seated against the flat portion of the “D” shaped portion of the auger shaft.



Convection Blower Removal



Make sure the stove has fully cooled (approximately 25 minutes) before conducting service. Unplug the stove to prevent electrical shock.



The removal steps are the same for both blowers however there are additional steps to gain access to the blower on the left-hand side of the stove. If you are only removing the right-hand blower, see the instructions for the removal of the Power Control Board (PCB).



The (2) blowers have different orientations and different part numbers. Make sure you are ordering the correct part. **The fans are named “Left” or “Right” based on facing the front of the stove.**

1. Remove the side panel (see section “Side Panel Removal”).
2. Disconnect the wiring (orientation of the wires does not matter when re-connecting)



3. Remove the (3) 3/8” screws that mount the blower and shroud to the stove body (set aside for reinstallation). The side (2) can be removed with a nut driver; the top (1) will require a small ratchet or a box wrench.





4. Remove the blower and shroud from the stove and remove the (4) 1/4" screws that secure the blower to the mounting bracket (set aside for reinstallation).





Combustion Blower Removal



Make sure the stove has fully cooled (approximately 25 minutes) before conducting service. Unplug the stove to prevent electrical shock.

1. Remove the left side panel (see section "Side Panel Removal").
2. Locate the combustion blower just inside the side opening of the stove, beside the exhaust plenum (see below)

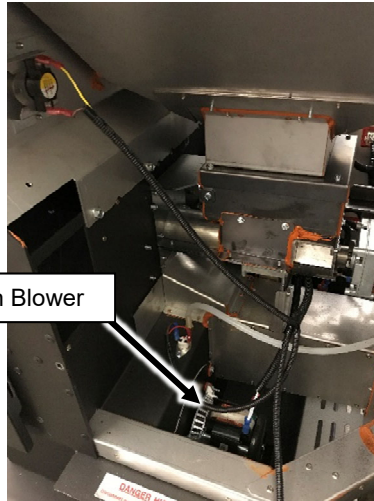

3. Locate the two wires that power the fan motor. Disconnect the wires from the motor. Make sure not to damage the connectors on the wires while removing.
4. Use a 1/4" nut driver to remove the screws that secure the access plate at the bottom, rear of the stove as shown below (set aside for reinstallation).





5. Disconnect the exhaust blower from the stove by removing the (6) bolts with a 5/16" nut driver. The top three are accessible from above and the bottom three can be reached through the access that was uncovered in the step above. **Set bolts, washers, and orange spacers aside for reinstallation.**

Top three screws accessed from top

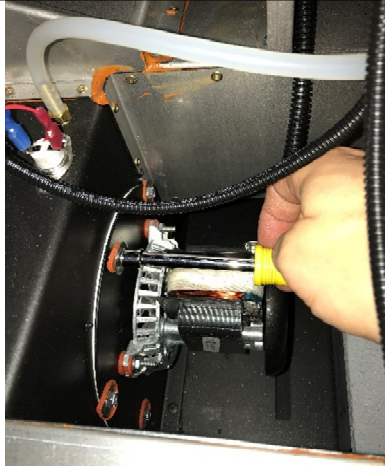

Bottom three screws accessed from rear access.



6. Carefully move the blower backward until the impellers are clear of the exhaust housing and remove the blower from the stove. Take care not to damage or bend the exhaust blower impellers.



Flow Switch Removal



Make sure the stove has fully cooled (approximately 25 minutes) before conducting service. Unplug the stove to prevent electrical shock.

1. Remove the left side panel of the stove (see section “Side Panel Removal”).
2. The Flow Switch is located behind the PCB. Removal of the PCB is not required but its removal will give better access to the Flow Switch (see section “PCB Removal”).
3. Use a 3/8” nut driver to remove the two locknuts that mount the switch to the rear panel of the stove (set aside for reinstallation).



4. Disconnect the two wires from the wiring harness at the quick connects (orientation does not matter for reinstallation).





5. Remove the vacuum hose from the flow switch





Metering Motor Removal



Make sure the stove has fully cooled (approximately 25 minutes) before conducting service. Unplug the stove to prevent electrical shock.

1. Remove the left side panel (see section "Side Panel Removal").
2. Remove the Power Control Board and heat shield (see section "Power Control Board Removal").

OR

Remove the blower (see section "Blower Removal") to gain access to the retaining screw.

3. Disconnect the two wires on the motor from the wire harness at the quick connects.
4. Use a 3/16" Allen wrench to loosen the retaining screw. If you only remove the screw enough to allow the shaft of the motor to become free, the collar and spacer will stay in place making for easier re-installation of the auger motor.

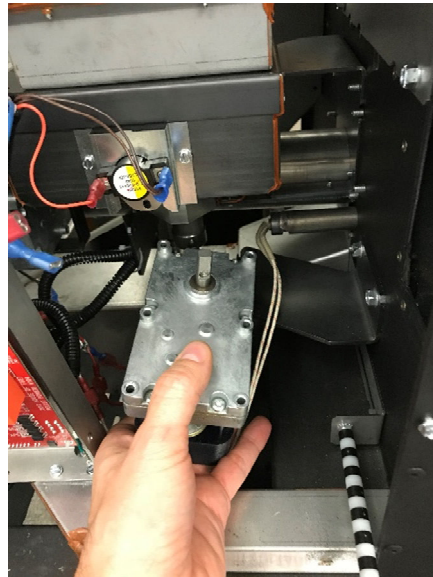
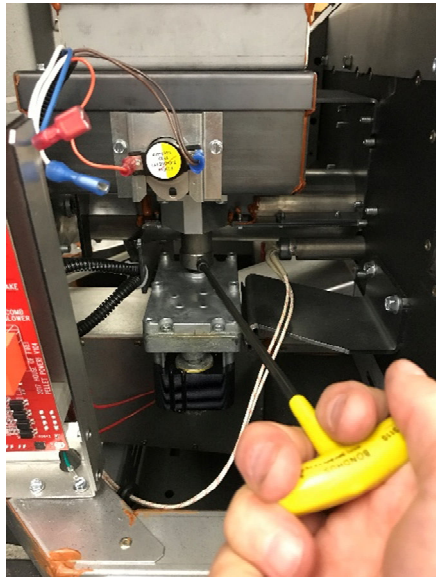
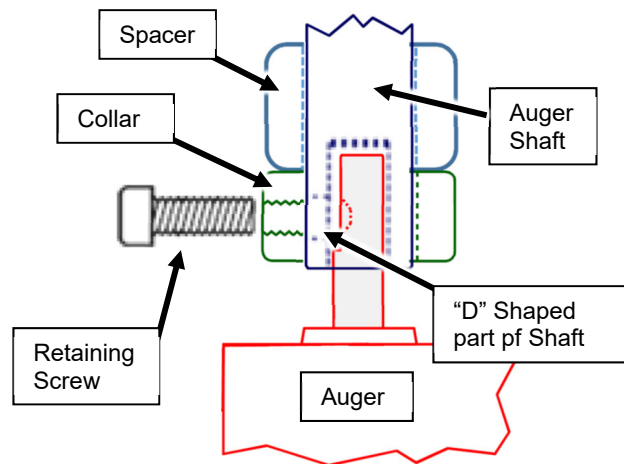

NOTE: When re-installing the auger motor make sure that the retaining screw is seated against the flat portion of the "D" shaped portion of the auger shaft.



User Interface (UI) Removal



Make sure the stove has fully cooled (approximately 25 minutes) before conducting service. Unplug the stove to prevent electrical shock.

1. Remove the left side panel (see section “Side Panel Removal”) or the rear panel on a Deerfield (see section “Rear Panel Removal”).
2. Pull the PCB forward to release it from the shield (see “PCB removal”).
3. Disconnect the AC power harness from the upper left corner of the board so you can tilt the board forward and gain access to the back of it.



4. Disconnect the UI board harness from the back of the DCB.

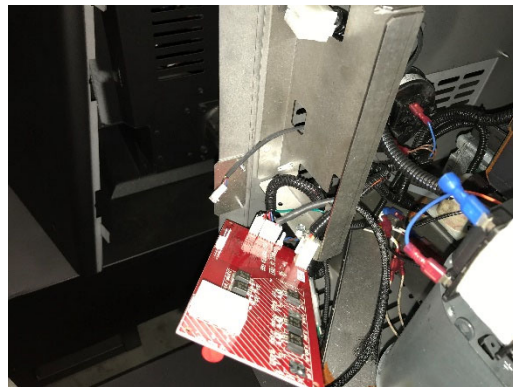
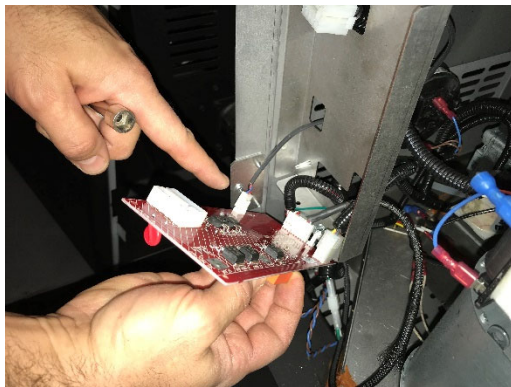

5. Remove the rubber grommet where the harness enters the hopper, on the backside of the stove behind the left hopper door hinge (set aside for re-installation).

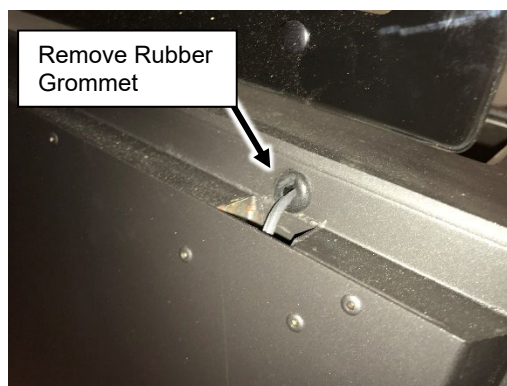



6. Pull the wire up into the hopper.



7. Use a 3/8" ratchet to remove the nut, inside the hopper, that secures the right hopper hinge to the stove (see below). Move the UI to the right and it will disengage from the bracket on the stove.

NOTE: Make sure to not drop the nut or washer into the hopper, it could jam the HRD.

NOTE: When re-installing the UI make sure the washer is in place between the hinge and the bracket.

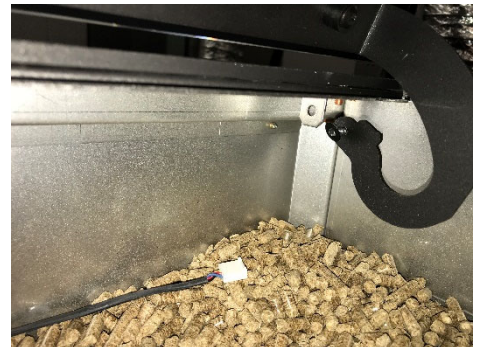
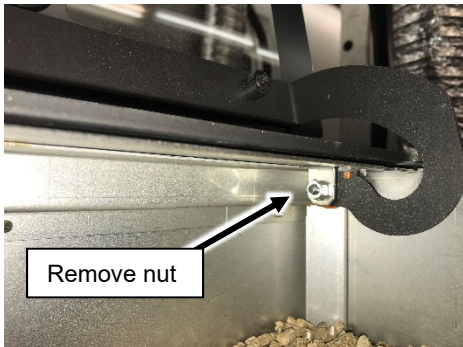



Troubleshooting the Appliance



Make sure the stove has fully cooled (approximately 25 minutes) before conducting service. Unplug the stove to prevent electrical shock.

Our new generation of pellet stoves is equipped with a unique control system that simplifies the troubleshooting process. Each stove has a “Power Control Board” (PCB) that has indicator lights that indicate the status for all of the safety control sensors on the unit (see below). It also indicates the status of power being distributed to the AC powered components in the appliance.

Pellet Power PCB vA00 Indicators

v103

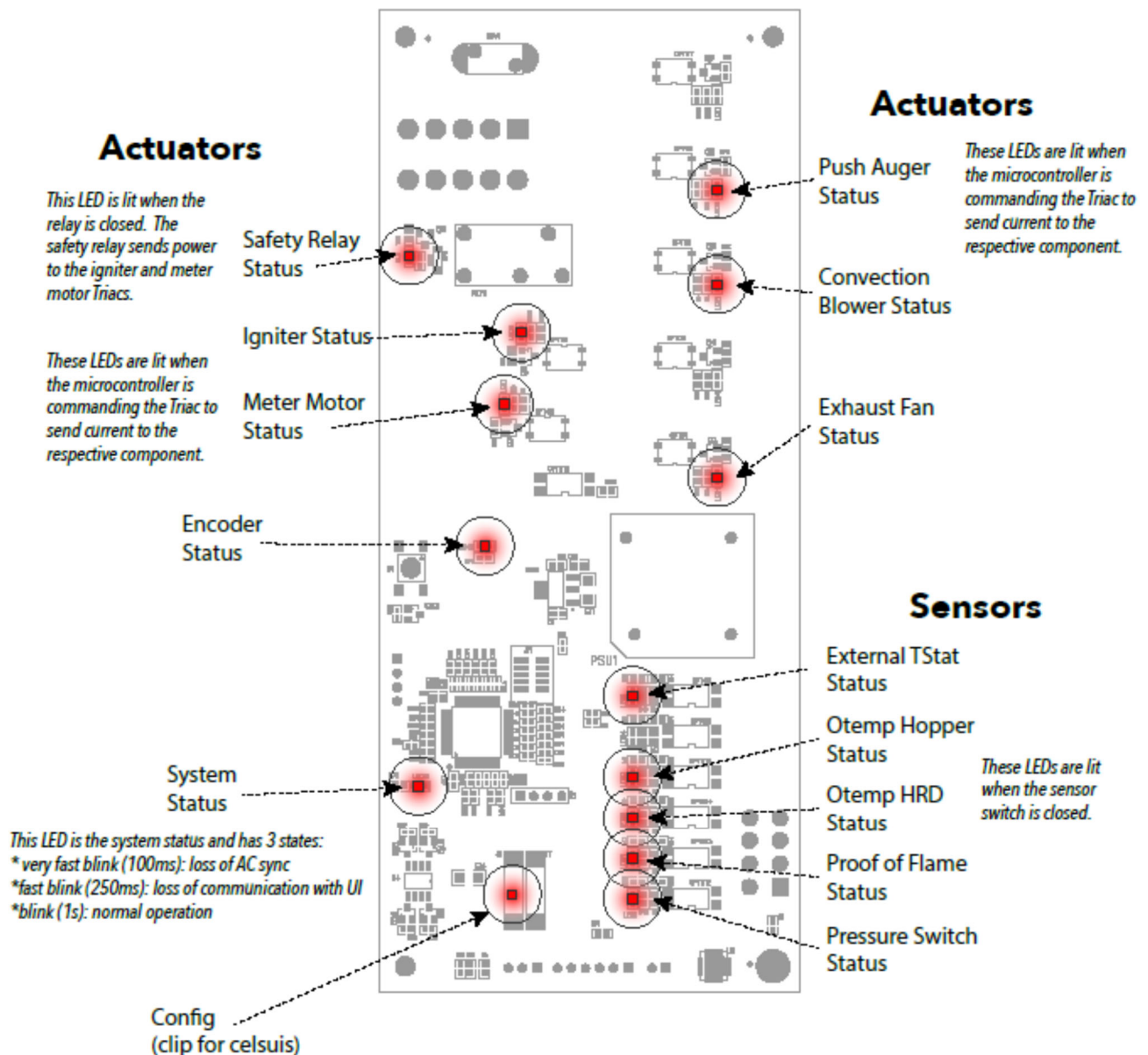



Diagnostic Screens for User Interface Firmware Version 1.2.2 or less

There are a few diagnostic screens . . .

There are also a few "secret" informational screens. These are to help troubleshooting. To access these screens, press and hold the menu button. While holding the menu button, swipe to the right for the Hour meter, and left for the Version Info

1. Hour Meter

*Shows the total number of hours the unit has burned.
Swipe right to show average time for the last 16 ignitions*

Hour Meter

4 Hours.

2. Ignition Time

Shows the average time for the last 16 ignitions

Avg Start Time

Time: 7:23

3. Fault Memory

*Shows up to 6 of the latest faults that occurred.
Swipe right to scroll through the memories.*

Fault Memory 1

Loss of Flame

32 hours ago

4. Version

*Shows version for UI PCB and Power PCB.
They don't necessarily have to match.*

Version

UI: 1.0.0

Power: 1.0.0



Diagnostic Screens for User Interface Firmware Version 1.2.3

<p>To access the diagnostic screens on stoves using the Firmware Version 1.2.3 you must access the “Dealer Service Mode”. This area of the menu is password-protected to ensure that homeowner does not make unintended changes to the settings. To access the Dealer Service Mode press the menu button 4x until you see the screen to the right.</p>	
<p>The “Dealer Service Mode” code is 425. To enter the code, press the first illuminated LED on the “Heat Setting” slider 4 times until to change the first number. Enter the other two numbers in the same manner. After all three numbers have been entered press the two illuminated LEDs on the right end of the “Heat Setting” slider.</p> <div style="border: 1px solid black; padding: 5px; display: inline-block; margin: 10px 0;"> <p>CODE = 425</p> </div>	
<p>The first screen in the Dealer Service Mode allows the selection of the internal or external thermostat. The stove is set to use the internal thermostat by default. Press the illuminated LEDs under the desired selection and/or press the Mode button to proceed to the next screen.</p>	
<p>The next screen shows the Hour Meter for the stove. The time displayed represents the total number of hours the stove has run. Press the Mode button to proceed to the next screen.</p>	



The next screen displays the Average Start Time. The time shown indicates the average time it has taken to sense ignition for the last 16 start cycles of the stove. Press the Mode button to proceed to the next screen.

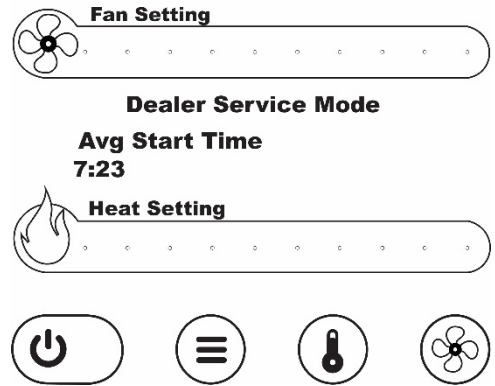

The next screen displays error codes or "faults" that the stove has experienced. The stove displays the last 6 faults sensed by the control board. The amount of time that has passed since the fault occurred is also displayed. There are 6 LED lights illuminated on the Heat Setting slider (each light represents one fault). Touch the LED's one at a time to cycle through the Faults. Press the Mode button to proceed to the next screen.

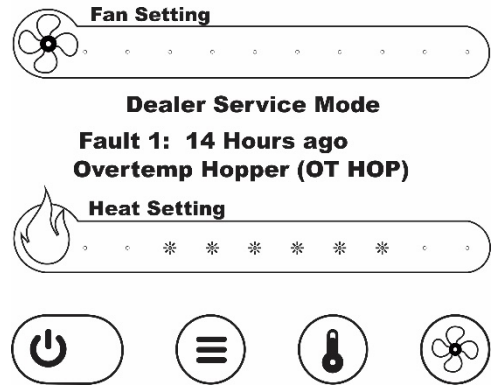

The last screen displays the Firmware versions of the User Interface and the Power Control Board. You can press the menu button to cycle through the screens or do not touch the board for 15 seconds and it will time out and exit the Dealer Service Mode.

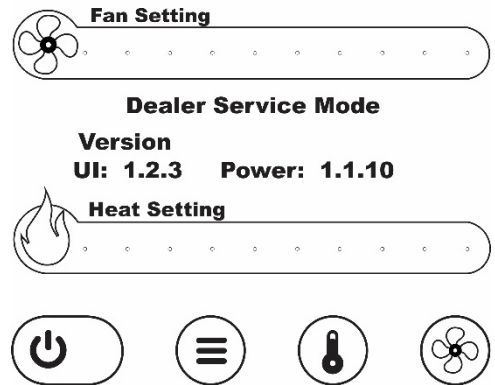



User Interface Error Codes

Service Overtemp Hopper (OT HOP)



- Check LED's on PCB for OT Hopper Snap Disk. LED ON means the disk is in the normally closed position or has not been triggered by heat.
- Perform a complete cleaning service of the appliance.
- Check the convection fans for malfunction or overheating.

Service Overtemp HRD (OT HRD)



- Check LED's on PCB for OT Hopper Snap Disk.
- Perform a complete cleaning service of the appliance.
- Check the convection fans for malfunction or overheating.

Service Loss of Flame (POF)



- Check to make sure there are pellets in the hopper.
- Check the System Snap Disk for proper operation. LED on means the disk is closed/hot

Continue on next page



Service

Auger Motor (ENCODER)



- Check the “Encoder Status” light on the PCB. If the light is on – the board is receiving the proper signal back from the encoder.
- Check LED on PCB for the Push Auger Status. LED on means power is being sent to the motor.
- Check that the motor is turning.
- Check to see if HRD is jammed.
- Check the voltage being sent to and coming back from the encoder on the PCB (see “Testing DC voltage from the Push Auger Encoder” section).

Service

Missed Ignition (POF)



- The igniter LED on the PCB should be on, indicating power going to the igniter.
- Clean the burn platform.
- Check to make sure there are pellets in the hopper.
- Check The voltage at the AC power pins (see testing AC power)
- Check voltage at the quick connects to the igniter.
- Check the System Snap Disk for proper operation
- Check wires for damage.
- Disconnect wires from the igniter and test resistance. Should be 52Ω to 67Ω (out of range = replace)

Service

Loss of Pressure (APS)



- Check the Pressure Switch Status LED on the PCB (on means the switch is closed).
- Check “Exhaust Fan Status” light on the PCB (On means the PCB is trying to send AC Power).
- Check for gasket leaks around the door.
- Check for gasket leaks around the glass.
- Check for gasket leaks at combustion blower
- Look for obstructions in the intake air.
- Check for buildup on the burn platform.
- Make sure the burn platform is in place properly.



Sensor Status Lights

When starting the troubleshooting process, the first thing to check the User Interface (UI) board, (touch controls on the hopper lid) and see if there are any fault codes. Make note of the codes and clear them by pressing the power switch 2 times. The display should say “Clearing” and then the stove will go into cool down mode. Press the start button again to begin the startup process and pay close attention to the AC components in the appliance. Make note of what runs and what does not before the fault code reappears on the control board. Armed with this information, follow the steps below to narrow down where the problem lies.

1. Locate the PCB and check the System status light. The status light should be blinking at a rate of (1) flash per second. If it is flashing faster, you may be having an issue with the UI board or the wires going to it. Check the wire for damage and check the connection to the PCB. If you cannot resolve the fast flashing code, replace the UI board.
2. Check the status lights of the sensors. If all sensors are working properly and the stove is cold the status should be as follows:
 - a) TStat Status – This light indicates whenever the thermostat is calling for heat. Light on indicates a call for heat, light off indicates a no call for heat. The light will function the same way if you are using the internal or external TStat.
 - b) OTemp Hopper status– This light indicates the status of the Hopper High Limit Disk or Overtemp Disk. Since this disk is a “Normally Closed” or NC disk, this light should be lit. If it is not then a continuity test should be done on the disk. Disconnect the wires from the disk and use the “tone” setting or measure resistance in Ohms (Ω). If you measure resistance or get tone when touching the two posts on the disk then the disk is not the problem. Check the wires for damage and continuity.
 - c) OTemp HRD status – This disk operates the same as the OTemp Hopper disk but it sensing the temperature on the Horizontal Rotating Disk assembly (HRD). Follow the steps above in the OTemp Hopper status section for this disk as well.
 - d) Proof of Flame status – This indicates the status of the “System Disk” aka the “Proof of Fire Disk”. This disk is a “Normally Open” or NO disk. When the stove reaches temperature, the disk proves to the PCB that the stove has actually lit by sensing the temperature change on the firebox. If the stove is cold, the light should not be on. If the light is on, the PCB believes that the stove has fire in it and will start to feed pellets into the burn platform. The Convection blowers will also be on. Symptoms of this disk being stuck on would be:
 - Overflowing pellets off the burn platform.
 - Convection blower coming on as soon as power is supplied to the stove.
 - Combustion blower that does not shut off at all.
3. Pressure Switch Status – This light shows the status of the Pressure or Flow switch. The flow switch has a diaphragm inside of it. When vacuum is supplied to one side of the diaphragm, the diaphragm moves and completes the electrical circuit, which sends an electrical signal to the PCB and proves that the fan is operating. If the appliance is running, the switch should be on. Whenever the Combustion fan is operating, the light should be on.

When a **COLD** stove is trying to run but the Pressure switch is not activated, the PCB will provide power to the combustion blower and the push auger for 15min as part of the “Fault Post Purge”. The push auger is always in operation when the exhaust blower is on. The PCB will not distribute power to any other AC powered component during this purge.

When a **HOT** stove has an APS fault, the same process will occur but there will be one additional step. The HOT stove will go into a “Fault Cooldown” mode until the system disk (aka Proof of Fire) closes. At that point, the stove will enter the “Fault Purge” mode for 15min. After the 15min, the stove will enter a “Fault Idle” mode (power light will alternate between Red and Green. An error code will show on the UI board and will need to be manually cleared before the stove will attempt to operate again. To clear the



code, press the power button once. Press the power button one more time to restart the stove.

If the pressure switch seems to be the issue, use a jumper to bypass the switch and see if the stove runs (make sure not to leave the stove with the jumper in place. This is a troubleshooting step only). If the jumper resolves the fault and allows the stove to run, check the following:

- Check for an obstruction in the venting.
- Check the vacuum hose for cracks and/or obstructions.
- Check the barbed nipple that is threaded into the exhaust plenum. Sometimes debris gets in the nipple and obstructs the vacuum. Clean the Barbed nipple and reinstall.
- Check the gasket on the door and ash pan door for leaks
- Check the glass gasket for leaks
- Check the gasket on the exhaust blower for leaks.

4. If a component is working but there is no indication on the status lights, you can check the board to see if the lights are working properly. To check the safety sensors status lights on the PCB, perform the following test.

- Disconnect the (8) pin Molex connector from the back of the lower right of the board (see section "Removal of PCB").
- On the front side of the board, use a jumper to touch the lower right pin (ground) and touch the other end of the jumper to each of the (4) left-hand pins. One light should light up with each of the pins being touched. If status lights do not light during this test, replace the board.

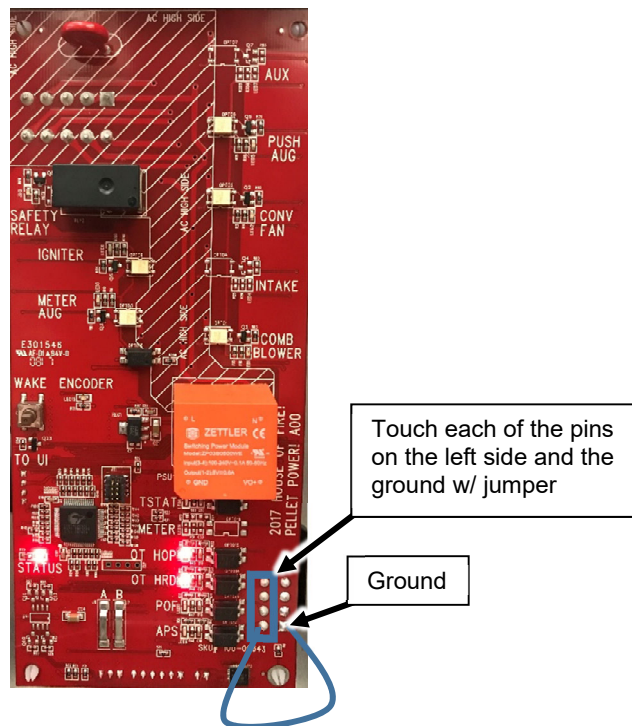



AC Status Lights

The status lights for the AC components tell you when the board is sending power to the component, not if the component is working properly. If you find that a particular component is not working (i.e. the push auger motor is not turning), check the status light for the component and see if the board is sending power. If the light is on, use a Multimeter to test the power at the AC Pins on the board that corresponds to the component in question (see section "Testing AC Power at the Board"). If the appropriate power is present at the pins on the PCB, test voltage at the component and see if power is reaching it. If power is not present at the component, the stove most likely has a wiring harness issue and you should test continuity between the board and the component. If power is present, the component is likely bad. Use a test cord to supply power directly to the component to verify your findings.

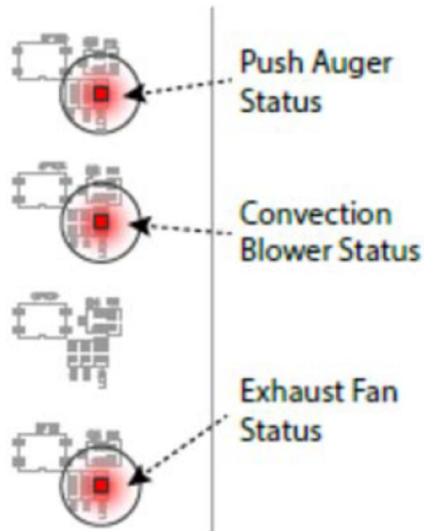



Testing AC Power at the Board



This portion of the PCB discussed in this section deals with high voltage. Only qualified personnel should test this portion of the board.

To test the AC power leaving the PCB us a Multimeter at the pins indicated below.

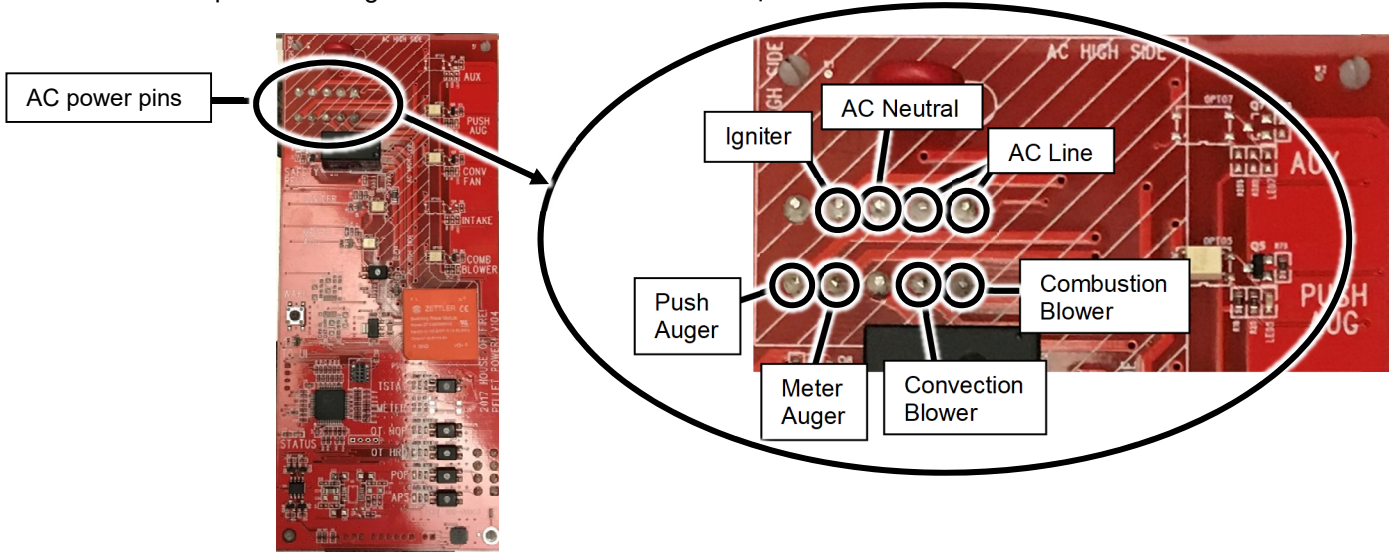

Touch the AC Neutral pin with the black lead from your Multimeter and use the red to touch the other pins to verify the voltage that is actually being sent to the component.



Testing DC voltage from the Push Auger Encoder.

The push auger is equipped with a device called an encoder. It receives a voltage signal from the PCB (5VDC) and sends a (2.5VDC) back to the PCB to prove to the PCB that it is operating properly. If the PCB does not get the correct signal from the encoder, it will not allow the metering auger to turn. To test the DC power that is going to the encoder and the voltage being sent back to the PCB set your Multimeter to read DC volts.

1. Touch one lead to the left pin and the other to the right pin. You should read approximately 5VDC at this point.
2. Touch one lead to the left pin and the other to the center pin. You should read 2.5VDC. (See illustration below).

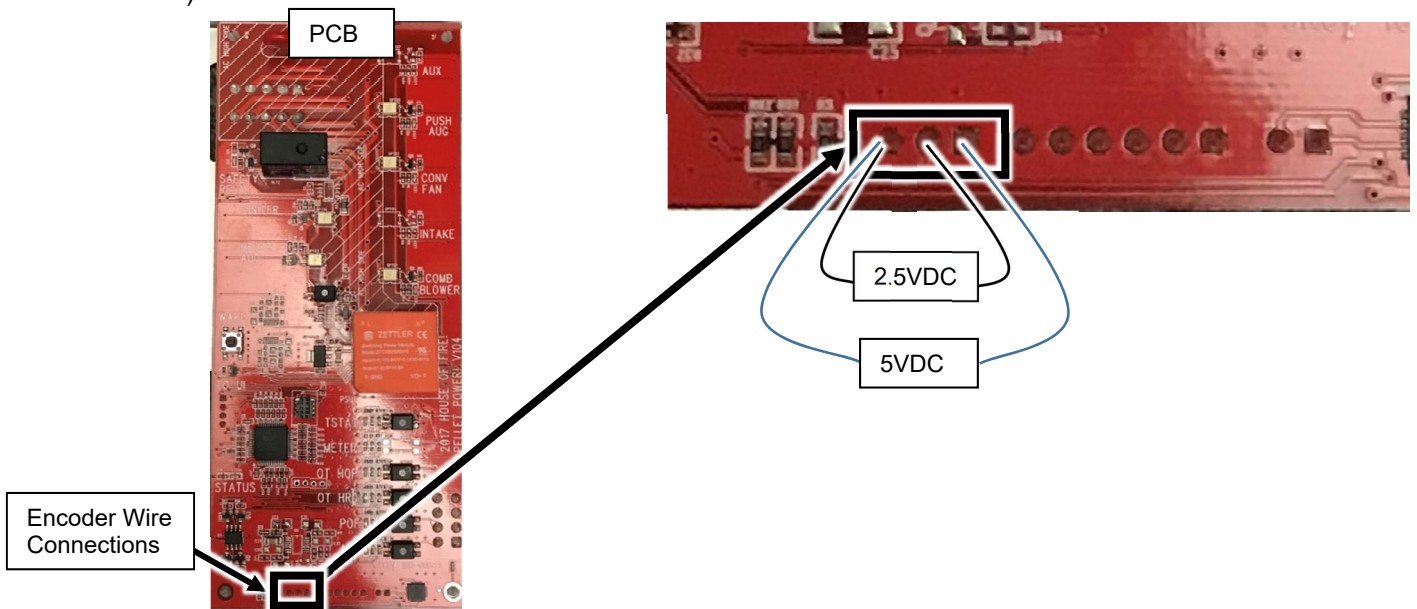

3. If you measure 5VDC going from the board but do not measure 2.5VDC coming from the encoder, make sure the push auger is turning. If it is, check the encoder wire connections to the PCB and the connector where the wires connect to the push auger motor.
 - If 5VDC is present but the 2.4VDC is not and wires and connections are not the issue, this would indicate a faulty encoder and the push auger motor should be replaced.
 - If 5VDC is not present – Replace the PCB.



Testing DC voltage from the Temperature Sensor

The temperature sensor functions by receiving voltage from the PCB and returning a smaller voltage signal back to the PCB. The amount of voltage that the sensor sends back to the board is a direct relationship to the temperature at the sensor (10mV = 1°Celsius). The temperature sensor can be checked for proper operation by testing the DC voltage at the appropriate pins on the board. To test the temperature sensor follow the steps below:

1. Touch one lead to the left pin and the other to the right pin. You should read approximately 5VDC at this point. The 5VDC is the voltage that the PCB is sending out to the sensor. If 5VDC is not present then replace the board.
2. Touch one lead to the center pin and the other to the right pin. You should get a mV reading on your meter that will vary based on the temperature at the sensor (See illustration and example below). 10mV = 1°Celsius.

Example:

1. You take a reading between the center pin and the right pin and get a reading of 210mV.
2. 10mV = 1°Celsius so divide the 210mV by 10mV and you get 21°Celsius
3. **To convert Celsius to Fahrenheit** you multiply the Celsius reading by 1.8 and then add 32 to the total so:
 $21^{\circ}\text{C} \times 1.8 = 37.8$
 $37.8 + 32 = 68.9^{\circ}\text{F}$

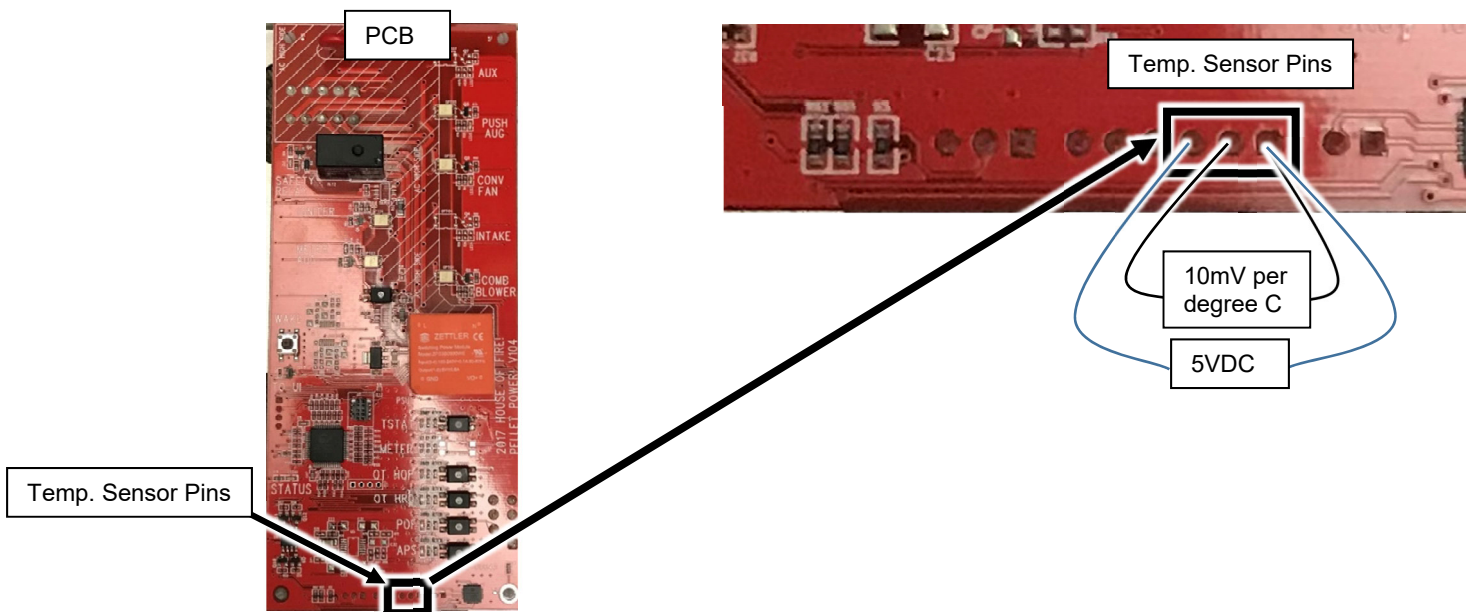

NOTE: The temperature reading is the temperature at the sensor, which is in close proximity to the stove, so it may read differently than another thermometer somewhere else in the room. If you are trying to determine if the sensor is reading correctly you should use another thermometer near the location of the stoves sensor to compare the reading.

NOTE: If the board is showing a reading of 32°F it would indicate a disconnected or grounded sensor.
If the board is showing a reading of around 140°F it would possibly indicate the 5VDC shorted on the sensor.



Normal Operation Flow Chart

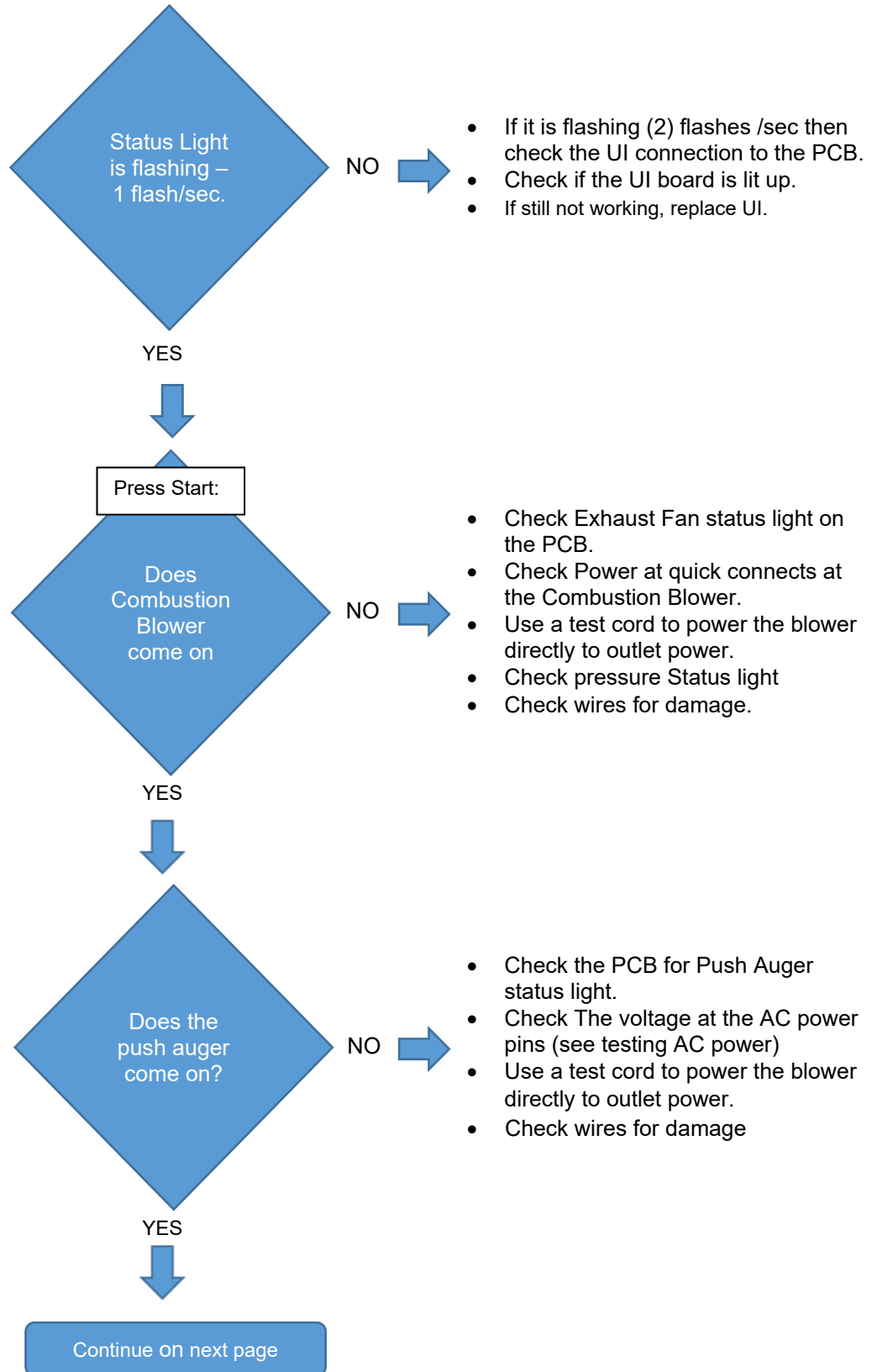

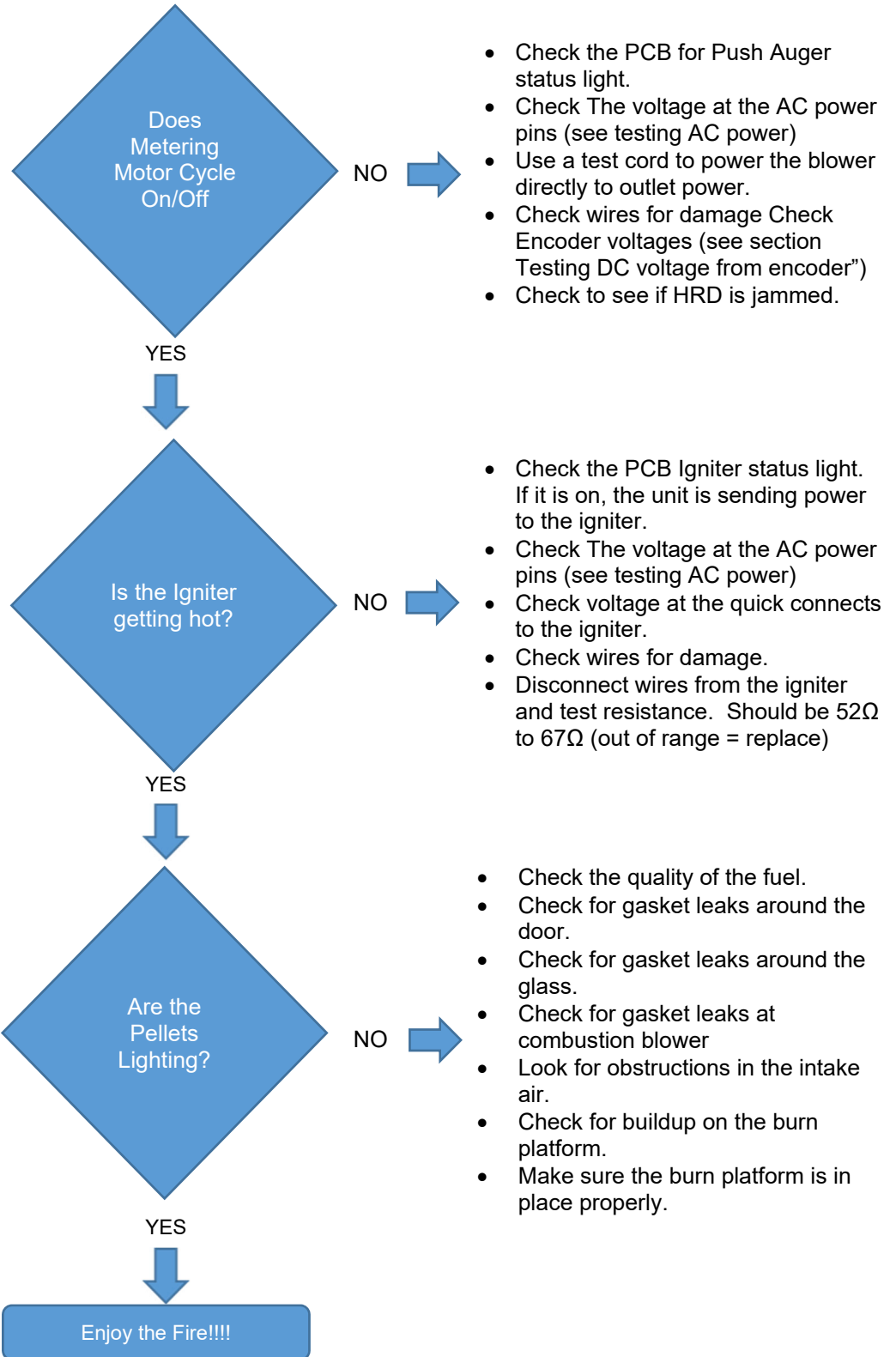

Depending on environmental conditions, cleanliness of the stove, fuel quality, and condition of gasket material this process may take between 4-15 minutes.



Annual Service

The following section details extensive maintenance procedures. We strongly suggest these items be carried out by a trained service technician.

NOTE: Pellet quality may vary by supplier. The maintenance schedule may need to be revised to accommodate the pellets used.



Make sure the stove has fully cooled (approximately 45 minutes) before conducting service. Unplug the stove to prevent electrical shock.

Introduction

Pellet stoves are inherently complicated devices. They work on precisely metered fuel and air and the movement of those two things, as well as the heat produced by the appliance, require each of the components of the stove to be operating as designed. The biggest obstacle to that occurring is the lack of regular maintenance.

The owner of the stove, on a weekly basis, should perform maintenance. If this maintenance is not performed, the stove will burn less efficiently, create more particulate matter, produce less heat, and have a shorter component life. Whether or not the regular maintenance is being performed, it is imperative that service is done by a professional on an annual basis.

This section will cover areas of the stove that need to be serviced but it does not address proper methods for protecting the customer's home from dust and soot that get disrupted while performing service. It is the responsibility of the person performing this maintenance to properly utilize drop cloths, soot vacuums, other forms of dust control, and personal protective gear while dealing with the byproducts of the combustion process.

Below are the steps that we would recommend for an annual service:

- Clean the venting system
- Clean convection blowers
- Clean vacuum tube to the flow switch (including barbed nipple)
- Clean the firebox, liners, and burn platform
- Clean the horizontal exhaust passage
- Clean the Exhaust Blower Impellers and Housing
- Check gaskets
- Clean fines out of the HRD

Recommended Tools for Service

- Pellet brushes and flexible rods
- Ash vacuum
- Drop cloths
- Magnetic drop light
- Variety of small brushes for inside the firebox and blowers (small paintbrushes and bottle brushes work well)
- Personal protective gear
- Nut drivers and screwdrivers
- Calk gun

Recommended Supplies for Service

- RTV silicone caulk
- Aluminum Tape
- Replacement Gasket
- Replacement Exhaust Box Cleanout Gasket (Deerfield)
- Door and Glass Gasket Material and Gasket Cement



Clean the Venting System

1. Inspect the venting system prior to performing any cleaning. Check for loose or unsealed joints to help ensure that dust does not escape when the venting is being swept down. Make note of caps on cleanout tees.
2. Go to the termination of the vent system and remove the cap. Clean the cap thoroughly. This part of the system accumulates a lot of soot because it is the coldest part of the vent system.
3. Use a properly sized pellet brush for the vent and sweep the pipe down to the cleanout tee.
4. Remove the cap on the cleanout tee and vacuum the debris out of the pipe. Replace the cap and reseal with aluminum tape.
5. Clean horizontal sections of pipe back to the stove.

Clean convection blowers

Cleaning the convection blowers improves their ability to move air efficiently. Cleaning the blowers helps move more heat into the house, prolongs the life of the blower, and keeps the area that contains other electronic components cooler during operation.

1. Use a brush to remove debris from the impellers of the blower. Use one hand to keep the impeller from turning while brushing the scooped area of the impeller blades.



NOTE: Handle the impellers gently. If an impeller becomes bent or damaged, it will no longer be balanced and will cause noise during operation and will need to be replaced.

2. Vacuum the blower area and the blower motor. Removing debris from the motor will allow the blower to run cooler.



Clean and Inspect Vacuum Tube

The vacuum tube communicates the negative pressure of the exhaust blower to the pressure switch. Obstruction of the tube, the barbed nipple that connects the tube to the exhaust housing, or a cracked tube can cause the flow switch not to function properly.

1. Remove the left side panel (Foxfire) or the rear panel (Deerfield) to gain access to the flow switch.
2. Remove the Vacuum tube from the stitch and blow compressed air through the hose back toward the exhaust housing.

NOTE: DO NOT blow air into the flow switch. The switch runs on very small amounts of pressure, blowing air or using compressed air can damage the diaphragm.

3. Remove the vacuum tube from the barbed nipple on the exhaust housing.

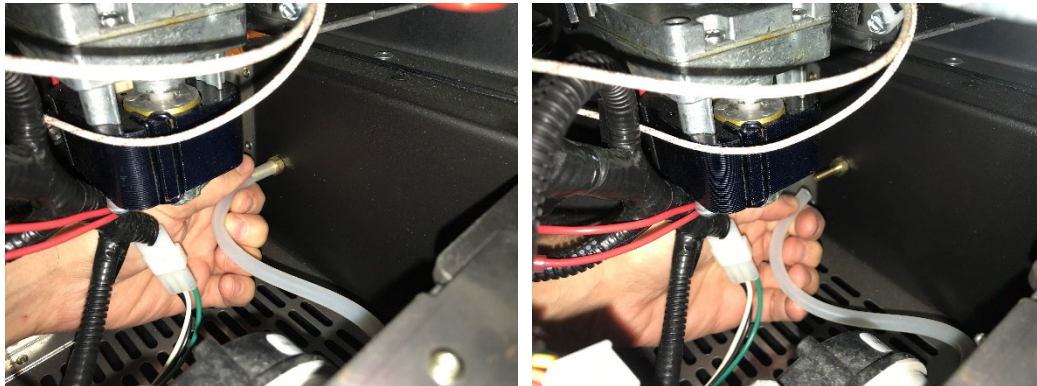

4. Use a crescent wrench or box wrench to remove the barbed nipple and clean any debris out of the interior portion.



Clean the firebox, liners, and burn platform

The firebox, ashpan, liners, and burn platform will likely be one of the dirtiest parts of the system. Cleaning this portion of the appliance stirs up a lot of dust and you will need to pull dirty components out of the firebox so use plenty of drop cloths. Brush soot off the firebox components before completely removing them from the firebox to help contain dust.

NOTE: We recommend keeping an ash vacuum running and put the hose right at the door to the firebox while performing cleaning in the firebox area. This will help control the dust while cleaning.



1. Open the door of the stove and vacuum the air wash just inside the door opening (see below).



2. Remove the visual deflector from the burn platform. Brush it clean and set aside for reinstallation. Vacuum off the burn platform, scrape it clean with the stove tool provided with the stove or other scraper. Make sure all the holes are free from obstruction.



3. Remove the burn platform from the firebox and set aside for reinstallation. Vacuum the ignitor area below the burn platform.





4. Start at the ceiling of the firebox and sweep the soot off the liners, top, sides, and rear. You can either vacuum up the debris as you go or just sweep everything down into the ash pan area or remove it at the end.



5. Remove the fireback liners from the firebox (see section "Fireback Removal"). Sweep the backside of each piece as you remove it from the stove.





6. With the Firebacks removed, the cast-iron heat exchanger and the metal firebox are now exposed. Start at the ceiling of the firebox and sweep the heat exchanger. Sweep the sides and back of the firebox as well.



7. Reach in and vacuum up the dislodged debris.



8. Open the ashpan door and remove the pan from the stove.

NOTE: Vacuum the ashpan as you remove it to help dust and soot entering the home.



9. Vacuum the area below and around where the ashpan sits below the firebox.



Clean the horizontal exhaust passage

Deerfield	<p>Remove the access cover by removing the wing nut on the left of the cover and pulling the left side forward. Slide the cover out of the stove.</p>		
	<p>Locate the exhaust port on the right side. Vacuum up all loose debris</p>		
Foxfire	<p>Remove the access cover by lifting up in the top center and guiding it out of the stove. Remove the circular cover-plate by removing the wingnut</p>		
	<p>Vacuum the horizontal channel</p>		



Clean the Exhaust Blower Impellers and Housing (Deerfield)

A thorough cleaning of the Exhaust Blower Impellers and Housing is vitally important to the stoves ability to burn cleanly and efficiently.

Deerfield GEN 1 Combustion Blower	<p>Remove the access plate and gasket from the side of the exhaust box</p> <p>NOTE: You will need to have a replacement gasket for reinstallation.- SKU# 250-04450</p>		
	<p>Gently brush the impellers the then vacuum the debris</p>		

Deerfield GEN 2 Combustion Blower	<p>Remove the access plate and gasket from the side of the exhaust box</p> <p>NOTE: You will need to have a replacement gasket for reinstallation.- SKU# 250-05310</p>		
	<p>Gently brush the impellers the then vacuum the debris</p>		



Clean the Exhaust Blower Impellers and Housing (Foxfire)

A thorough cleaning of the Exhaust Blower Impellers and Housing is vitally important to the stoves ability to burn cleanly and efficiently.

Foxfire	Gently brush the impellers the then vacuum the debris		
----------------	---	---	---

Check gaskets

Leaking gaskets can cause poor performance in pellet appliances. If air can enter the firebox through a leak then it is not being pulled through the burn platform and burning fuel. Leaking gaskets can also cause an ignitor to not light the pellets properly as well. The following gaskets should be checked annually:

- Door Gasket
- Glass Gasket
- Ashpan Door Gasket
- Exhaust Blower Gasket

The door and glass gaskets will often show leaks easily if you know what to look for. Generally, a leak in either of these two places will cause a clean streak on the glass where the air is entering.



Clean fines out of the HRD

Fines or sawdust debris from pellets can accumulate in the HRD over time. Humidity in the air can cause the fines to swell and can impede the movement of the disks. We recommend the HRD be opened and cleaned annually.

For details on how to access and open the HRD, see section "Horizontal Rotating Disks (HRD) Components Removal".

Make sure to vacuum out the following areas on the HRD assembly:

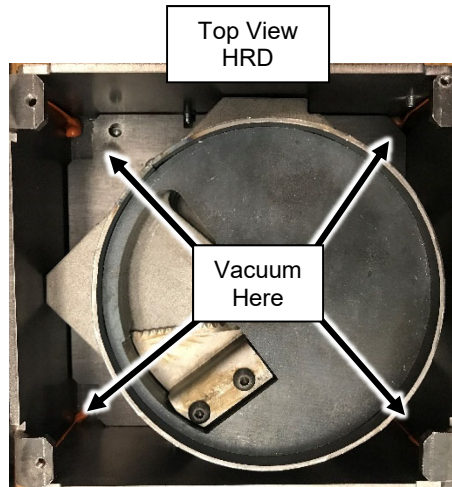

Take care to reassemble the HRD with all components in the same order **AND** make sure not to turn any of the components upside down. Improper reassembly could cause performance issues and could be a safety hazard.



Appendix A

Wiring Diagram

FOXFIRE / DEERFIELD WIRING

POWER BRANCH

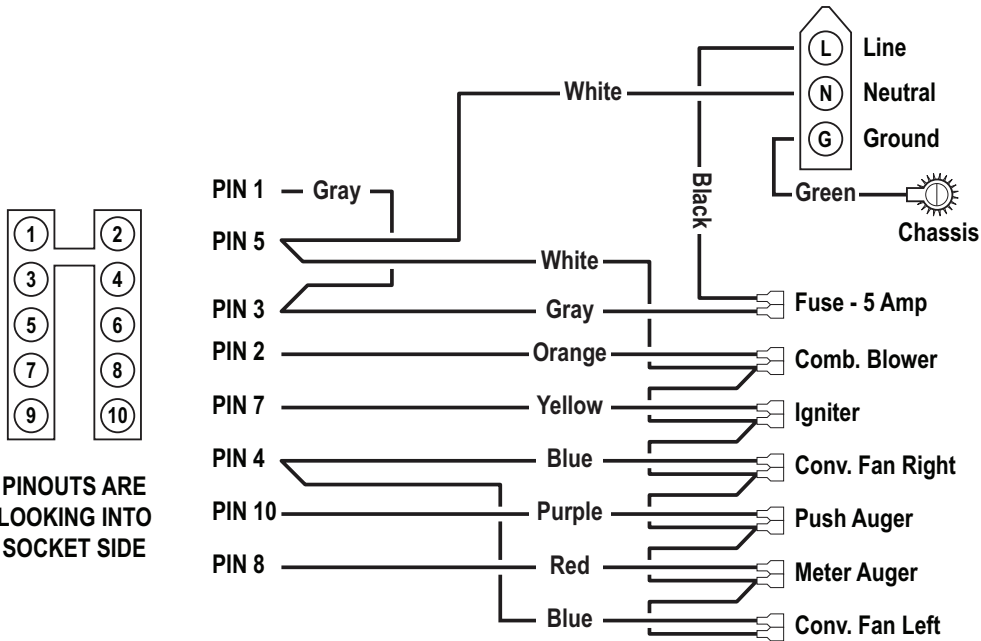

SAFETY BRANCH

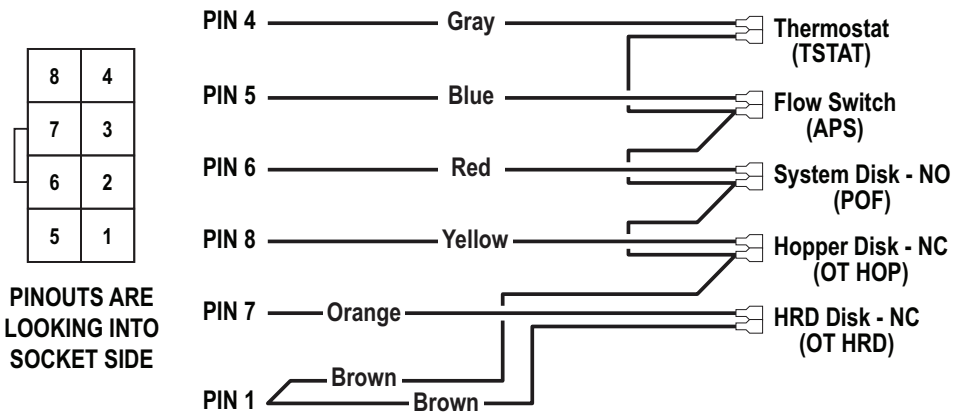

NOTE: text in parenthesis match power control board printed characters



Appendix B

Control Timing

Pellet firmware v1.1.7 Timings

vA01

* combustion fan starts at level 1 for 60 seconds, then level 2 for 30 seconds, then level 3 for 30 seconds.

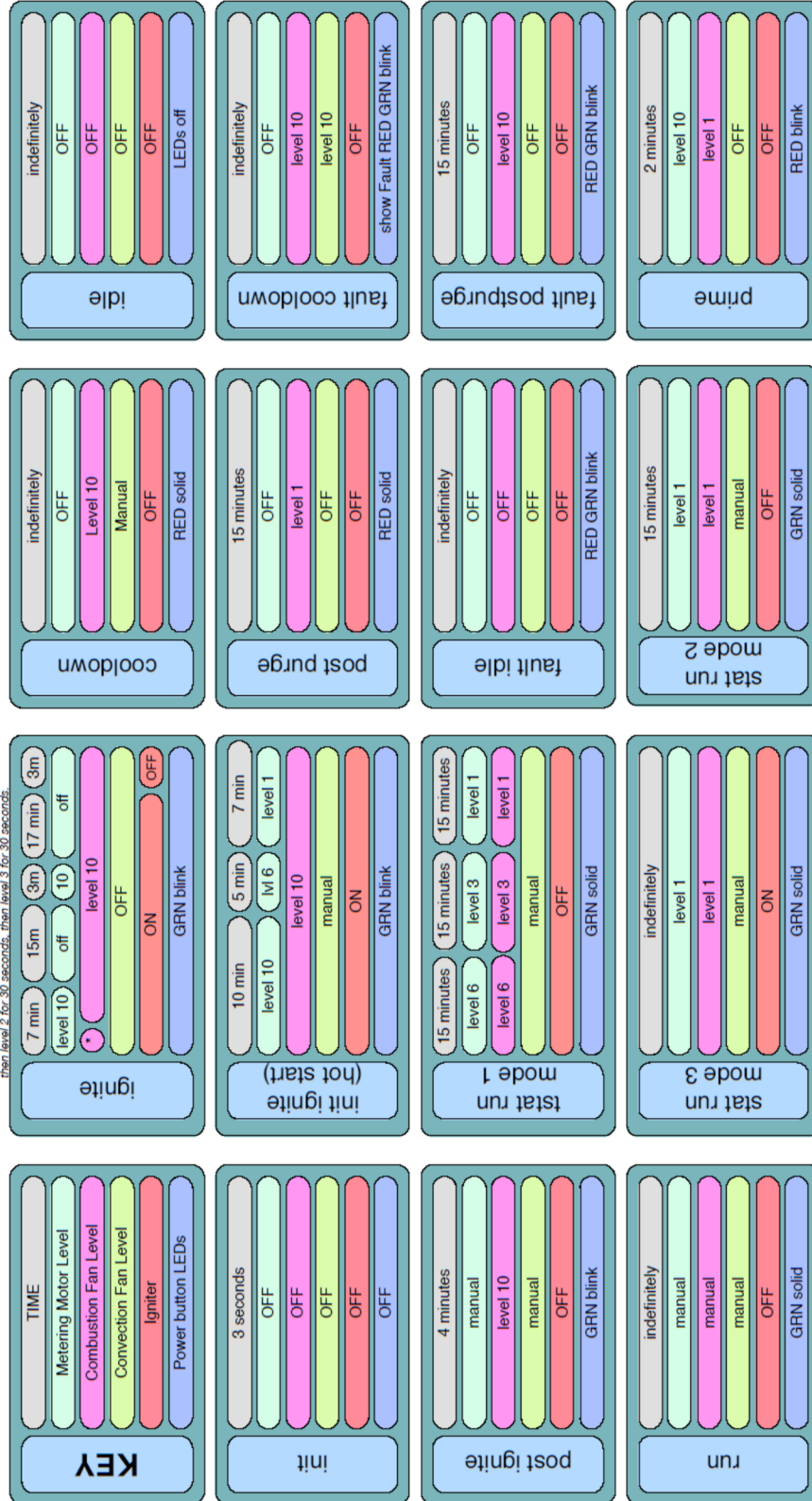



Appendix C

Fan Voltages and Metering Motor Timing (FW 1.1.7)

Voltages and Timings for v1.1.7 FW

LEVEL	CONV LOW	CONV HIGH	EXHAUST	METER TIMINGS
<i>1</i>	90	95	95	148
<i>2</i>	92	100	100	124
<i>3</i>	93	103	105	100
<i>4</i>	95	105	110	80
<i>5</i>	100	110	115	63
<i>6</i>	105	112	120	49
<i>7</i>	110	115	120	35
<i>8</i>	110	120	120	22
<i>9</i>	110	120	120	18
<i>10</i>	110	120	120	12

Use **CONV LOW** when heat level is 5 or less; use **CONV HIGH** otherwise.

METER TIMINGS are in seconds, and represent the “OFF time”. “On time” is 45 seconds.

Voltages assume 120VAC power source, measured using a True RMS voltmeter under load, and are approximate.



Fan Voltages and Metering Motor Timing (FW 1.1.10)

Voltages and Timings for v1.1.10 FW

LEVEL	CONV LOW	CONV HIGH	EXHAUST w/ Jumper	EXHAUST w/o Jumper	METER TIMINGS
1	90	95	89	99	124
2	92	100	89	102	111
3	93	103	90	104	98
4	95	105	90	108	85
5	100	110	91	111	72
6	105	112	92	115	59
7	110	115	93	116	47
8	110	120	94	119	35
9	110	120	95	120	23
10	110	120	95	120	12

Use **CONV LOW** when heat level is 5 or less; use **CONV HIGH** otherwise. **METER TIMINGS** are in seconds, and represent the “OFF time”. “On time” is 45 seconds.

Voltages assume 120VAC power source, measured using a True RMS voltmeter under load, and are approximate.



Appendix D

Power Control Board Pinout

Pellet Power PCB vA00 Pinouts

v100

